



**CIVILITY PLEDGE**

*The way we govern ourselves is often as important as the positions we take. Our collective decisions will be better when differing views have had the opportunity to be fully vetted and considered. All people have the right to be treated with respect, courtesy and openness. We value all input. We commit to conduct ourselves at all times with civility and courtesy to each other.*

**ALAN HALLMAN**  
MAYOR

**MIKE RAST**  
ALDERMAN AT LARGE

**BRETT REICHERT**  
COUNCILMAN AT  
LARGE

**MARK ADAMS**  
COUNCILMAN WARD I

**CHASE STELL**  
COUNCILMAN WARD II

**MAYOR AND COUNCIL WORK SESSION**

Join in person at 700 Doug Davis Drive, Hapeville, GA 30354 Or, visit the City's Website for live stream at <https://hapeville.org/562/Agendas-and-Minutes>

January 20, 2026 6:00 PM

**AGENDA**

**1. CALL TO ORDER:**

**2. ROLL CALL:**

Alan Hallman  
Mike Rast  
Brett Reichert  
Mark Adams  
Chase Stell

**3. WELCOME:**

**4. PRESENTATIONS:**

4.I. Recognition of Hapeville Elementary School's CCRPI Achievement and National Recognition.

**Background:**

Hapeville Elementary School will be recognized for outstanding academic achievement and national distinction. The school recently received a CCRPI (College and Career Ready Performance Index) score of 81.9 (B), reflecting significant progress in performance as measured by Georgia public school standards. Additionally, Hapeville Elementary has been named a U.S. News and World Report Best School for 2026—for the second consecutive year.

**5. PUBLIC HEARING:**

**6. QUESTIONS ON AGENDA ITEMS:**

The public is encouraged to communicate their questions, concerns, and suggestions during Public Comments. The Council does listen to your concerns and will have Staff follow-up on any questions you raise. Any and all comments should be addressed to the Governing Body, not to the general public and delivered in a civil manner in keeping with common courtesy and decorum.

**7. CONSENT AGENDA:**

7.I. Consideration and Action to Approve December 9, 2025, Mayor and Council Meeting Minutes.

**Supporting Document(s):**

1. Drafted Minutes 12092025

7.II. Consideration and Action to Approve January 6, 2026, Mayor and Council Meeting Minutes.

**Supporting Document(s):**

1. Drafted Minutes 01062026

**8. OLD BUSINESS:**

**9. NEW BUSINESS:**

- 9.I. Consideration and Action to Enter into an Agreement with U.S. Soccer Foundation for the Construction of a Mini Pitch System on the Tennis Court that's adjacent to Scout Street next to Hapeville Elementary.

**Background:**

Developed in partnership with the U.S. Soccer Foundation, the Mini Pitch System is designed to create safer, more accessible spaces for playing soccer. This initiative focuses on transforming abandoned courts and other underutilized areas into vibrant community hubs where children and families can gather to enjoy teamwork, empowerment, and physical activity. The grant, totaling **\$100,000.00**, is fully funded by the sponsor and does not require matching funds or reimbursement. The only expense incurred by the city will be limited to minor electrical work.

**Supporting Document(s):**

1. City of Hapeville Mini-Pitch Grant Agreement
2. Mini-Pitch System Modular Sports Solution Brochure
3. Mini-Pitch Identify Your Site

- 9.II. Consideration and Action to Approve the Purchase of the Sutphen Heavy Duty 75' Rear Mount Aerial Ladder Truck.

**Background:**

The Fire Department is requesting approval to purchase a 75-foot Sutphen SLR-75 aerial quint in the amount of **\$1,885,768.56** to support the expanding operational needs of the Special Tax District.

Our current aerial resource (the E-One 95' platform) has proven unreliable. The SLR 75 would allow us to transition aging apparatus into reserve roles while retiring outdated equipment. Additionally, only Station 2 currently has a bay capable of housing a modern ladder/quint, and this limitation has been transparently communicated as part of our long-term facility planning.

Recent updates to the district include 14 additional commercial structures, along with the reinstatement of Best Western and In City Suites, both of which exceed 80–100 feet in height and require reliable aerial fire suppression and rescue capability. The district now includes numerous multi-story residential units with limited access, hotels, mixed-use buildings, parking decks, and commercial occupancies ranging from 32 to 110 feet, driving the need for consistent ladder service..

Given the district's rapid vertical growth, operational challenges (setbacks, apparatus positioning, overhead power lines, large footprints), and the long build time of 20–22 months, the purchase of the SLR 75 is both necessary and time-sensitive.

**Supporting Document(s):**

1. Hapeville GA SLR75 Proposal Package Revised with Loose Equipment

**10. CITY MANAGER REPORTS:**

**11. PUBLIC COMMENTS:**

Members of the public wishing to speak shall sign in with the City Clerk prior to the start of the meeting. Time limitations for Registered Comments are three (3) minutes per person. The total Registered Comment session shall not last more than fifteen (15) minutes unless extended by Council. Each member of the public, who fails to sign up with the City Clerk prior to the start of the meeting, wishing to address Mayor and Council shall have a total of two (2) minutes. The entire general comment session for Unregistered Comments shall not last more than ten (10) minutes unless extended by Council.

**12. MAYOR AND COUNCIL COMMENTS:**

**13. EXECUTIVE SESSION:** *When Executive Session is Required one will be called for the following issues: 1) Litigation O.C.G.A. §50-14-2; 2) Real Estate O.C.G.A. §50-14-3(b)(1); or 3) Personnel O.C.G.A. §50-14-3(b)(2).*

**14. ADJOURN:**

Public involvement and citizen engagement is welcome as Hapeville operates a very open, accessible and transparent government. We do however remind our attendees/residents that there are times allocated for public comments on the agenda. In order for council to conduct their necessary business at each meeting, we respectfully ask that side-bar conversations and comments be reserved for the appropriate time during the meeting. This will allow the City Council to conduct the business at hand and afford our meeting attendees ample time for comments at the appropriate time during the meeting.



**CIVILITY PLEDGE**

*The way we govern ourselves is often as important as the positions we take. Our collective decisions will be better when differing views have had the opportunity to be fully vetted and considered. All people have the right to be treated with respect, courtesy and openness. We value all input. We commit to conduct ourselves at all times with civility and courtesy to each other.*

**ALAN HALLMAN**  
MAYOR

**MIKE RAST**  
ALDERMAN AT LARGE

**BRETT REICHERT**  
COUNCILMAN AT  
LARGE

**MARK ADAMS**  
COUNCILMAN WARD I

**CHLOE ALEXANDER**  
COUNCILMAN WARD II

**MAYOR AND COUNCIL REGULAR SESSION**

Join in person at 700 Doug Davis Drive, Hapeville, GA 30354 Or, visit the City's Website for live stream at <https://hapeville.org/562/Agendas-and-Minutes>

December 9, 2025 6:00 PM

**MINUTES**

1. **CALL TO ORDER:** by Mayor Hallman at 6:04 PM.
2. **ROLL CALL:** All members of the Council were present, thereby constituting a quorum.
  - Alan Hallman
  - Mike Rast
  - Brett Reichert
  - Mark Adams
  - Chloe Alexander
3. **WELCOME:** Mayor Hallman welcomed all to the December 9<sup>th</sup> meeting.
4. **PLEDGE OF ALLEGIANCE:** The Pledge of Allegiance was recited in unison.
5. **INVOCATION:** Given by Councilman Brett Reichert.

**AMEND AGENDA:**

**MOTION:** Councilman Adams made a motion to amend the agenda by adding an item under **Presentations:** *Ring Ceremony and Recognition of the 5U, 6U, and 8U Football Teams for their championship wins and advancements to the national level.* Alderman Rast provided a second. **The motion carried with a vote of 4-0.**

6. **PRESENTATIONS:**
  - 6.I. Ring Ceremony and Recognition of the 5U, 6U, and 8U Football Teams for their championship wins and advancements to the national level.

Director of Parks and Recreation, Tod Nichols, introduced and recognized the City's championship youth football teams. He called forward the 5U team coached by Juan and the 6U Sting team coached by Hassan, along with their coaching staff and players. Both teams recently secured championship titles.

Mr. Nichols also noted the 8U team had advanced to the National Championships and was currently in Florida competing. Additionally, the 5U and 6U teams are scheduled to travel to Florida to represent Hapeville in their respective national tournaments.

Coach Hassan briefly addressed the Mayor and Council, thanking parents for their continued support throughout the season and commending the players for their hard work and dedication. He acknowledged the team's 6-2 record and highlighted their one-point championship win as a testament to their perseverance.

7. **PUBLIC HEARING:** There were no public hearings item(s) during this meeting.
8. **QUESTIONS ON AGENDA ITEMS:** There were no questions on agenda items at this meeting.

## AMEND AGENDA:

**MOTION:** Councilman Reichert made a motion to amend the agenda by adding an item under **Consent Agenda: Consideration and Action to accept the \$45,000 grant from the Georgia Recreation Parks Association by way of the Georgia Department of Education;** Councilman Adams provided a second. **The motion carried with a vote of 4-0.**

### 9. CONSENT AGENDA:

- 9.I. Consideration and Action to accept the \$45,000 grant from the Georgia Recreation Parks Association by way of the Georgia Department of Education.

**MOTION:** Alderman Rast made a motion to approve the consent agenda; Councilman Alexander provided a second. **The motion carried with a vote of 4-0.**

### 10. OLD BUSINESS: There were no old business items at this meeting.

### 11. NEW BUSINESS:

- 11.I. Consideration and Action to Approve the new Butterfly Lantern Parade Route.

**MOTION:** Alderman Rast made a motion to approve the new Butterfly Lantern Parade Route; Councilman Alexander provided a second. **The motion carried with a vote of 4-0.**

- 11.II. Consideration and Action to Approve the Mayor and Council 2026 Meeting Schedule Ordinance. — Second Reading. **Ordinance 2025-14**

**MOTION:** Councilman Adams made a motion to approve the Mayor and Council 2026 Meeting Schedule (**Ordinance 2025-14**); Alderman Rast provided a second. **The motion carried with a vote of 4-0.**

- 11.III. Consideration and Action to Approve the IGA with Fulton County for the Recreation Football Field.

**DISCUSSION:** Councilman Reichert opened the discussion by inquiring about the expiration and potential delay of the current IGA. Parks & Recreation Director, Tod Nichols, confirmed the agreement expires December 31st, 2025, and that a delay would not affect programming since events do not begin until summer.

Councilman Reichert expressed concern over potential land ownership discrepancies and the City bearing full responsibility for upgrades and maintenance without compensation from Fulton County. Using Fulton County Assessor maps, he noted that portions of the gym and recreational facilities appear to be built on City property, and he recommended pausing the renewal to explore a renegotiated agreement. He suggested the City consider proposing a land swap for ownership of the stadium in exchange for the land the school currently occupies.

Councilman Adams and Alderman Rast echoed support for renegotiating an agreement that brings more accountability and access to residents. Councilmembers noted that City taxpayers are funding the upkeep of facilities that are not currently accessible to the public.

Councilman Alexander voiced a key concern about the City's long-term investment in the parcel. She emphasized that millions of dollars have been spent on its maintenance and suggested a formal agreement include provisions for **reversion of the property to the City** in the event Fulton County uses the parcel for another purpose in the future. She added that such a clause would satisfy both current operational needs and future ownership protection.

Mayor Hallman supported the idea and suggested the inclusion of a **right of first refusal** clause. He noted the City had previously invested in lighting, fencing, and irrigation systems for the field. He also acknowledged the increasing disconnect between the City and Fulton County as leadership and staff have changed over time.

City Attorney, Lajuana Ransaw, advised that GIS data is not definitive and recommended conducting a formal **survey and title search** to determine legal property boundaries and uncover any easement agreements. She estimated this process could take **60–90 days**.

**MOTION:** Councilman Reichert made a motion table this item for 90 days pending legal review and property research; Councilman Adams provided a second. **The motion carried with a vote of 4-0.**

11.IV. Consideration and Action to Approve the Delta Memorial Easement Agreement.

**MOTION:** Councilman Adams made a motion to approve the Delta Memorial Easement Agreement; Councilman Reichert provided a second. **The motion carried with a vote of 4-0.**

11.V. Consideration and Action on Lease of the Fulton County Health Building, 3444 Claire Drive.

**MOTION:** Alderman Rast made a motion to approve the Lease of the Fulton County Health Building, 3444 Claire Drive; Councilman Adams provided a second. **The motion carried with a vote of 4-0.**

**12. CITY MANAGER REPORTS:** There was no City Manager Report at this meeting due to the absence of City Manager Tim Young, who was under the weather.

**13. PUBLIC COMMENTS:**

1. Charlotte Rentz
2. Christan Baker
3. Bobby Wilson

**14. MAYOR AND COUNCIL COMMENTS:**

**Mayor Hallman** opened Council comments by recognizing that this meeting marked Councilman Chloe Alexander’s final official Council meeting. He commended her for eight years of dedicated service, noting her historic achievement as the first African American woman elected to office in Hapeville. He praised her leadership, advocacy for the arts, and selfless commitment to the city, calling her a trailblazer who left a lasting impact.

**Councilman Adams** echoed the Mayor’s sentiments, reflecting on their shared start in office and acknowledging Alexander’s thoughtful, unbiased approach to governance. He praised her for always prioritizing the good of the city, bringing objective ideas to the table, and serving with humility and professionalism.

**Councilman Reichert** added his appreciation, highlighting Alexander’s intelligence, leadership, and meaningful contributions, particularly her role in the community garden. He closed his comments with a heartfelt original poem in tribute to her service.

**Alderman Rast** reflected on the friendship and mutual respect developed over their time on Council, expressing appreciation for her insights and community spirit. He also recognized her engagement with the local school community and wished her and her family continued success.

**Councilman Alexander** then shared her own emotional farewell, expressing deep gratitude to her fellow Council members, city staff, and residents. She dispelled misconceptions she had heard before serving and praised the honesty, professionalism, and collaboration of the Council and staff. While acknowledging her personal reasons for stepping down, she emphasized that her decision was made with the city’s best interest in mind and expressed confidence in her successor. She thanked her colleagues for their friendship and support and noted she would miss the day-to-day interactions but would remain an active presence in the community.

**Mayor Hallman** concluded the remarks by reiterating the city’s appreciation for Councilman Alexander’s contributions, emphasizing the strength and unity of the current team, and wishing everyone a happy holiday season.

**15. EXECUTIVE SESSION:** *When Executive Session is Required one will be called for the following issues: 1) Litigation O.C.G.A. §50-14-2; 2) Real Estate O.C.G.A. §50-14-3(b)(1); or 3) Personnel O.C.G.A. §50-14-3(b)(2).*

**MOTION:** Councilman Adams made a motion to go into recess; Alderman Rast provided a second. **The motion carried with a vote of 4-0.**

**MOTION:** Councilman Alexander made a motion to go into executive session at 7:12 PM; Councilman Adams provided a second. **The motion carried with a vote of 4-0.**

**MOTION:** Councilman Alexander made a motion to convene back into regular session at 7:24 PM, Councilman Reichert second. **The motion carried with a vote of 4-0.**

**16. ADJOURN:** With no further business, Mayor Hallman called for a motion to adjourn.

**MOTION:** Councilman Alexander motioned to adjourn at 7:25 PM; Alderman Rast provided a second. **The motion carried with a vote of 4-0.**

Respectfully submitted,

---

Alan Hallman, Mayor

---

Sharee Steed, City Clerk



**CIVILITY PLEDGE**

*The way we govern ourselves is often as important as the positions we take. Our collective decisions will be better when differing views have had the opportunity to be fully vetted and considered. All people have the right to be treated with respect, courtesy and openness. We value all input. We commit to conduct ourselves at all times with civility and courtesy to each other.*

**ALAN HALLMAN**  
MAYOR

**MIKE RAST**  
ALDERMAN AT LARGE

**BRETT REICHERT**  
COUNCILMAN AT LARGE

**MARK ADAMS**  
COUNCILMAN WARD I

**CHASE STELL**  
COUNCILMAN WARD II

**MAYOR AND COUNCIL REGULAR SESSION**

Join in person at 700 Doug Davis Drive, Hapeville, GA 30354 Or, visit the City's Website for live stream at <https://hapeville.org/562/Agendas-and-Minutes>

January 6, 2026 6:00 PM

**MINUTES**

1. **CALL TO ORDER:** by Mayor Hallman at 6:01 PM.
2. **ROLL CALL:** All members of the Council were present, thereby constituting a quorum
  - Alan Hallman
  - Mike Rast
  - Brett Reichert
  - Mark Adams
  - Chase Stell
3. **WELCOME:** Mayor Hallman welcomed all to the January 6<sup>th</sup> meeting.
4. **PLEDGE OF ALLEGIANCE:** The Pledge of Allegiance was recited in unison.
5. **INVOCATION:** Given by Pastor Dier Hopkins.
6. **PRESENTATIONS:**
  - 6.I. Oath of Office – Administered by Honorable Fulton County Superior Court Judge Eric Dunaway.
    - i. Swearing-In for Councilman At Large, Brett Reichert
    - ii. Swearing-In for Councilman Ward I, Dr. Mark Adams

Honorable Judge Eric Dunaway administered the oath of office to Councilman At Large, Brett Reichert and Councilman Ward I, Dr. Mark Adams, officially inaugurating them into their respective roles.

  - iii. Swearing-In for Councilman Ward II, Chase Stell

Fulton County Commissioner Mo Ivy administered the oath of office to Councilman Ward II, Chase Stell, officially inaugurating him into his respective role.
  - 6.II. Hapeville Police Department 2025 Recognition Awards.

Police Chief Bruce Hedley presented the 2025 Annual Police Department Recognition Awards, honoring exceptional service, bravery, and commitment among the department’s officers and staff. Chief Hedley acknowledged the physical and emotional toll of leadership in public safety and highlighted the significance of each award.

**Award Recipients:**

    - **Supervisor of the Year:** *Corporal T. Moore*  
Recognized for his leadership, support to fellow officers, and dedication across all shifts. Promoted to corporal in March 2025, he was selected by his peers for his humility and positive attitude.

- **Civilian of the Year:** *Communication Officer Jackie Rodriguez*  
A 12-year veteran with the department, noted for her can-do attitude, strong work ethic, and consistent willingness to fill in during staffing shortages.
- **Meritorious Service Award:**
  - *Officer Ken Stevens* – Administered Narcan to save an overdose victim’s life.
  - *Corporal Shada Canzater (not present)* and *Officer Dennis Rowe* – Assisted in identifying and rescuing a human trafficking victim during a traffic stop.
  - *Corporal Colleran* and *Communication Officer A. Adams* – Intervened in a suicide attempt on the I-85 bridge, preventing a potential fatality.
- **Police Star Award** – For acts of heroism and bravery under direct threat:
  - *Lieutenant Barry Barnes, Sergeants M. Williams & A. Sangoveth, Corporals D. Smith & A. Moore, Officers A. Odom, D. Porter, C. Figgers, and Communication Officer Brittany Ayers*  
These officers responded to a barricaded gunman at the Hilton Hotel in June 2025. Despite being fired upon through a hotel door, the team-maintained control, evacuated guests, and coordinated with Fulton County SWAT to safely end the standoff.
- **Chief’s Meritorious Award:**
  - *Detective Narrell Workman* – For exceptional leadership during the Hilton Hotel standoff, overseeing on-scene command, coordinating multiple agencies, and ensuring proper evidence handling and prosecution coordination.
  - *Code Enforcement Sergeant Marjan Meyer (not present)* – For expertise in property code enforcement, training, and achieving high-impact outcomes throughout 2025.
- **Police Officer of the Year:** *Officer Michael Abercrombie*  
A former Cobb County firefighter, Officer Abercrombie transitioned to full-time policing in 2023. Honored for his dual role in traffic enforcement and handling critical IT, radio, and software infrastructure that supports department operations.

Chief Hedley commended all recipients for their outstanding professionalism and their continued contributions to public safety in the City of Hapeville.

6.III. Recognition of the 2025 Police Officer and Firefighter of the Year by the Exchange Club.

- i. **2025 Police Officer of the Year Award:** Officer Michael Abercrombie.
- ii. **2025 Firefighter of the Year Award:** Division Chief/Fire Marshal Jenny Brown.

Hapeville Exchange Club President Ruth Barr presented the 2025 Police Officer of the Year Award and the 2025 Firefighter of the Year Award to recipients selected in coordination with the Hapeville Police and Fire Departments.

- **Police Officer of the Year:** *Officer Michael Abercrombie*  
Ms. Barr acknowledged Officer Abercrombie’s outstanding service and emphasized the critical behind-the-scenes role of IT support in law enforcement.
- **Firefighter of the Year:** *Division Chief / Fire Marshal Jenny Brown*  
Fire Chief Nick Condrey introduced and praised Chief Brown, noting her appointment as Fire Marshal in November 2025. He highlighted her leadership, accountability, and completion of 14 advanced training courses during the year, including the Fire Officer and Fire Investigator programs. Chief Condrey stated that Chief Brown’s dedication to professional growth and service exemplified the values behind the award.

Ms. Barr also expressed the Exchange Club’s long-standing commitment to honoring first responders and emphasized their vital role in the community.

7. **PUBLIC HEARING:** There were no public hearings item(s) during this meeting.
8. **QUESTIONS ON AGENDA ITEMS:** There were no questions on agenda items at this meeting.
9. **CONSENT AGENDA:**
  - 9.I. Consideration and Action to Approve November 18, 2025, Mayor and Council Meeting Minutes.

- 9.II. Consideration and Action to Approve November 18, 2025, Executive Session Meeting Minutes.  
9.III. Consideration and Action to Approve December 9, 2025, Executive Session Meeting Minutes.

**MOTION:** Councilman Adams motioned to approve the consent agenda; Alderman Rast provided a second. **The motion carried with a vote of 4-0.**

10. **OLD BUSINESS:** There were no old business items at this meeting.

11. **NEW BUSINESS:**

- 11.I. Consideration and Action to Approve the Event Request for the “Bayou Bash”.

**MOTION:** Alderman Rast made a motion to approve the Event Request for the “Bayou Bash”; Councilman Stell provided a second. **The motion carried with a vote of 4-0.**

- 11.II. Consideration and Action to Approve the Organizational Appointments Ordinance. **Ordinance 2026-01**

- **City Attorney:** Andrew J. Welch, III, Lajuana C. Ransaw, and the attorneys at Smith, Welch, Webb & White, LLC
- **City Clerk:** Sharee Steed
- **City Solicitor:** Kim Cornwell
- **Public Defender:** Clarence Dameon Mitchell
- **City’s Legal Organ:** South Fulton Neighbor Newspaper
- **Official Publication:** South Fulton Neighbor Newspaper

**MOTION:** Councilman Stell made a motion to approve the Organizational Appointments Ordinance (**Ordinance 2026-01**); Councilman Adams provided a second. **The motion carried with a vote of 4-0.**

12. **CITY MANAGER REPORTS:** City Manager Tim Young welcomed the Mayor and Council to the first meeting of the year and extended a special welcome to newly seated Councilman Chase. In keeping with the brief nature of the meeting, Mr. Young provided a short update covering three main areas:

- **Audit Update:** The FY2024–2025 audit is set to begin next week. Mr. Young stated the City anticipates a clean audit and noted the importance of the past fiscal year, as it was critical for the City’s financial position.
- **Mid-Year Budget Review:** With half of the year’s revenue already received, staff have begun reviewing the current year’s budget in preparation for mid-year adjustments. Any necessary updates are expected to be brought before Council in February or March.
- **New Website Launch:** Mr. Young announced that the City has launched a new website, which features improved functionality and highlights Downtown Hapeville. [www.downtownhapeville.org](http://www.downtownhapeville.org)

13. **PUBLIC COMMENTS:**

1. Melvin Traynum

14. **MAYOR AND COUNCIL COMMENTS:**

**Councilman Stell** expressed gratitude to the citizens of Hapeville for electing him to serve on the City Council. He reflected on the positive experiences of engaging with the community during his campaign and shared appreciation for the support received throughout the process. He extended special thanks to outgoing Councilwoman Chloe Alexander, acknowledging the high standards she set during her two terms. Stell expressed excitement about working alongside the Mayor, fellow Councilmembers, and City staff. He also thanked his family, with particular recognition of his mother’s family history in Hapeville and gave personal acknowledgments to friends and supporters present at the meeting. He concluded by expressing heartfelt appreciation to his partner Olivia, noting that his election win was only the second-best moment of the year after meeting her.

**Alderman Rast** congratulated all award recipients and recognized the dedication of the police and fire departments. He welcomed Councilman Stell and expressed full confidence in his ability to fill the seat of Councilwoman Alexander. He also congratulated re-elected Councilmembers Reichert and Adams and looked forward to working collaboratively in the coming years.

**Councilman Adams** thanked the citizens for re-electing him to a third term and emphasized that

his re-election was a reflection of the collective spirit of Hapeville. He committed to serving with humility and integrity to continue moving the city forward.

**Councilman Reichert** thanked the voters for his re-election, despite running unopposed. He acknowledged the contributions of first responders, especially communications and code enforcement officers, who often work behind the scenes. Entering his second term, he reaffirmed his commitment to fair, smart, and inclusive decision-making, grounded in the city's diversity and values.

**Mayor Hallman** praised the dedication of newly sworn-in and returning councilmembers, noting the emotional weight and responsibility of public service. He acknowledged the unique nature of Hapeville's community and governance, highlighting that unlike other cities, Hapeville keeps ceremonies simple and focuses on service. He emphasized the value of the city's staff and thanked residents for their engagement and support.

**15. EXECUTIVE SESSION:** An executive session meeting was not conducted at this meeting.

**16. ADJOURN:** With no further business, Mayor Hallman called for a motion to adjourn.

**MOTION:** Councilman Adams motioned to adjourn at 6:58 PM; Councilman Stell provided a second.  
**The motion carried with a vote of 4-0.**

Respectfully submitted,

---

Alan Hallman, Mayor

---

Sharee Steed, City Clerk

**MINI PITCH PROGRAM**  
**DONATION AGREEMENT – FISCAL YEAR 2026**

Pursuant to this Mini Pitch Program Grant Agreement (“Agreement”), dated as of the December 8, 2025 (“Effective Date”), the United States Soccer Foundation, Inc. (“Foundation”) agrees to award the Grant (“Grant”) to the **City of Hapeville**, (“Grantee”) **FY26-779**, and Grantee accepts such Grant, in accordance with the terms and conditions set forth herein.

1. **Foundation:**                   **U.S. Soccer Foundation**  
Attn: Operations Department  
1140 Connecticut Ave. NW, Suite 1200  
Washington, DC 20036

**Grantee:**                           **City of Hapeville**  
Attn: Tod Nichols  
3444 N Fulton Avenue  
Hapeville, GA 30354

2. **Grant:** This Grant, awarded in the form of an interlocking tile mini pitch surface with goal and lighting installation (“Mini Pitch”), supplied by Musco Sports Lighting (“Vendor”), which shall be valued by Foundation, in its sole and absolute discretion, in the amount of **\$100,000**.

3. **Mini Pitch:** Consistent with Foundation’s interests in promoting youth soccer, particularly within vulnerable communities, this Grant will provide the Mini Pitch at the **Hoyt Smith Recreation Center** (the “Grant Project”).

4. **Execution of the Grant Agreement:** Grantee must return an executed copy of this Agreement to the Foundation by the January 9, 2026.

5. **Grantee Covenants:** In order to encourage Foundation to enter into this Agreement, and to award the aforementioned Grant, Grantee covenants as follows:

(a) Foundation will be granted usage of the Mini Pitch for one (1) day per year over the first five (5) years following its completion, including, without limitation, for Special Events (as defined below) that are organized by Foundation. Foundation will make best efforts to schedule such usage for dates and times mutually agreed upon with the Grantee, and Grantee will not unreasonably withhold play space time for such usage. For purposes of this Agreement, “Special Events” shall be defined as tournaments, clinics, events, training sessions, media functions and any other similar event the Foundation so determines.

(b) In preparation for the Mini Pitch installation, Grantee will provide necessary access to the Foundation’s Vendor, which includes, but is not limited to: identification and communication of underground utilities or other access issues related to the Vendor’s ability to access the Mini Pitch location via forklift, temporary removal of chain link fencing, and providing access for both freight truck parking for delivery and 2-wheel drive rubber tire equipment for installation at the designated location within the overall site. Additionally, Grantee will complete electrical work to provide power to the Mini Pitch either before installation commences or within 3 months of the installation completion. Such electrical work includes providing a 120-volt control circuit and lighting circuit.

Grantee will also provide an area on site for disposal of packaging materials prior to the Mini Pitch installation.

Should Grantee fail to provide such access and information, especially as it relates to underground utilities, the Foundation and Vendor shall not be responsible for damage caused by Vendor during installation. Additionally, if the Mini Pitch location is accessible only via grass pathways, Vendor shall not be responsible for potential damage to such grass pathway areas.

- (c) Upon completion of the Mini Pitch, Grantee acknowledges and agrees that it will be responsible for the maintenance and safety of the Mini Pitch.
- (d) Grantee presently owns, or is currently tenant to an appropriate long-term lease of, the property on which the Mini Pitch will be installed. An appropriate long-term lease shall mean a lease of at least ten (10) years in length following the Effective Date.
- (e) Prior to commencing installation of the Mini Pitch, Grantee will obtain, or shall assist (where necessary) in obtaining, all permits, authorizations and consents from third parties, including governmental entities, necessary for the installation of the Mini Pitch.

6. **Facts and Representations True and Correct:** Grantee hereby affirms the representations made in its conversations and communications with Foundation are true and correct and that Foundation may rely upon the truth and correctness of the representations made in all conversations and communications regarding this Grant Project, without further independent investigation. Grantee further affirms that it has not omitted any material facts, the knowledge of which would adversely impact the awarding of the Grant to Grantee. Grantee avows that no adverse events have occurred since the latest communication which have materially and adversely altered the truth or reliability of the Grant Project, including the tax status of Grantee and the Grantee's ability to allow successful completion of the Grant Project. Grantee agrees to immediately inform the Foundation within five (5) business days of any material change, in Grantee or the Grant Project, which might affect any terms of this Agreement.

7. **Grantee Books and Records:** Grantee agrees to maintain sufficient operating and financial books, records and related documentation regarding the activities of Grantee and other evidence sufficient for Foundation to satisfy its fiduciary, public and governmental responsibilities and duties. Foundation shall have reasonable access to the books and records of Grantee for inspection purposes and shall be entitled to copies, as they relate to the Grant Project.

8. **Grantee Reports:**

- (a) **Impact Reports:** Following completion of the Mini Pitch, Grantee shall complete to Foundation a report, provided by the Foundation, describing the impact of the Mini Pitch. Such report shall be submitted to Foundation annually, for five (5) years after completion of the Mini Pitch and shall include photographs of the Mini Pitch in use by youth soccer players and provide information on play space usage rates, stories of impact on the community, and any other information reasonably requested by Foundation.
- (b) **Site Visits:** Grantee will use its best efforts to accommodate any representative of Foundation who requests to conduct a site visit, at the sole cost of Foundation, for the purposes of collecting information about the Grant's impact.
- (c) **Photographs/Videos/Stories/Testimonials:** In addition to submitting digital photographs, videos, stories and testimonials relating to the Grant Project in the aforementioned Impact Reports, the Grantee shall submit the same to the Foundation upon request by the Foundation, including before and after photographs, both in daytime and at night, of the Mini Pitch site area.

9. **Publicity Material and Recognition:**

- (a) Grantee, upon written approval by the Foundation, shall recognize the Foundation and acknowledge the Grant in Grantee's written materials, news releases, website and related marketing or publicity.
- (b) The Foundation shall have the right to publicize, show photographs of, and use the name of the Mini Pitch and otherwise promote its contributions in any and all media, including the Internet. Grantee authorizes the Foundation to utilize those logo or logos, owned or controlled by Grantee and associated with the Grant Project, for related marketing and/or publicity.
- (c) Grantee agrees to fully assist and cooperate in a mutually acceptable dedication event, should the Foundation request such, which may include appearances by athletes affiliated with the Foundation.

10. **Awareness Opportunities:** Grantee grants to Foundation the right to permanently place Foundation's trademark, trade name or any design/logo owned or controlled by Foundation (each, a "Mark" and together, the "Marks"), and/or that of its funding partners, on the surface of the Mini Pitch. Unless Foundation chooses to forego the right, standard Marks will be included during installation of the Mini Pitch, per the rendering found in Attachment A. Foundation may change its Marks at any time in its sole discretion and at its sole cost. Each Mark will remain on the surface of the Mini Pitch for as long as the Mini Pitch is operational, unless removed by Foundation or unless Foundation otherwise gives its written consent to the removal of such Mark.

Additionally, Grantee will allow Foundation to install signs/banners on the premises on which the Mini Pitch is installed, per the rendering found in Attachment A, in order to promote and recognize the Foundation and other funders for their contribution to the Mini Pitch.

11. **Grant Not Assignable:** Grant is intended solely for the benefit of Grantee. No benefit of the Grant may be delegated, assigned or otherwise transferred without the advance, written consent of Foundation, which consent shall be in the sole and absolute discretion of Foundation.

12. **Proper Authority:** Each of the parties and its officers represent and warrant that they are authorized to enter into this Agreement and execute the same without further authority.

13. **Absence of Warranties:** FOUNDATION MAKES NO REPRESENTATIONS OR WARRANTIES OF ANY KIND, EITHER EXPRESS OR IMPLIED, AS TO ANY MATTER INCLUDING, BUT NOT LIMITED TO, IMPLIED WARRANTIES OF FITNESS FOR A PARTICULAR PURPOSE, MERCHANTABILITY OR OTHERWISE RELATING TO THE MINI PITCH OR ANY COMPONENT PART THEREOF, OR ANY OTHER ENTITIES AND THEIR ASSOCIATED SERVICES. IN NO EVENT WILL FOUNDATION BE LIABLE FOR ANY DAMAGES OF ANY KIND INCLUDING, BUT NOT LIMITED TO, PERSONAL INJURY, LOST PROFITS, OR OTHER CONSEQUENTIAL, EXEMPLARY, INCIDENTAL OR PUNITIVE DAMAGES ARISING OUT OF THIS AGREEMENT OR PERFORMANCE OF THE OBLIGATIONS HEREUNDER.

14. **Assumption of Risk:** Grantee hereby agrees to assume all risks and liabilities associated with the use, operation, maintenance, safety and condition of the Mini Pitch.

15. **Insurance Requirements:**

- (a) **Insurance Requirements of the Mini Pitch.** At all times while the Mini Pitch is in place, Grantee shall provide and maintain, at its expense, the following insurance, or appropriate self-insurance,

which shall protect Grantee and the Foundation on a primary basis from any and all Claims arising out of or in connection with the Grant Project and the Mini Pitch pursuant to this Agreement:

- (i) Commercial General Liability insurance with limits not less than \$1,000,000 each occurrence and \$2,000,000 in the aggregate. Such insurance shall include coverage for contractual liability, premises liability, products-completed operations, personal and advertising injury, property damage and bodily injury liability (including death). Said policy shall be endorsed to name the Foundation and Foundation Parties as Additional Insureds.
- (ii) Automobile Liability insurance covering liability arising out of the Grantee's use, operation and/or maintenance of any auto (including trucks and other construction vehicles), with limits not less than \$1,000,000 each accident combined single limit for bodily injury and property damage.
- (iii) Workers' Compensation insurance covering employees of Grantee involved with the use and maintenance of the Mini Pitch, with limits as required by statutory law, including Employer's Liability coverage with limits not less than \$1,000,000 each accident, \$1,000,000 disease-each employee and \$1,000,000 disease-policy limit.
- (iv) Umbrella and/or Excess Liability insurance with limits not less than \$2,000,000 each occurrence shall apply in excess of the Commercial General Liability, Automobile Liability and Employer's Liability policy limits.
- (v) Participant Accident insurance covering all Participants and other individuals using the Mini Pitch with limits not less than \$5,000 per participant for Accident Medical coverage and \$1,000 per participant for AD&D coverage.

All such insurance required above shall be (1) considered primary with respect to Claims arising out of the use and maintenance of the Mini Pitch; and (2) shall be written by insurance companies that are licensed to do business in the state in which the Mini Pitch is located. Grantee shall not allow any of the required policies to be materially changed, reduced or cancelled unless Grantee provides thirty (30) days prior written notice thereof to Foundation.

Upon execution of this Agreement, Grantee shall provide Foundation with a certificate of insurance confirming that the appropriate insurance is in place and that the policies have been properly endorsed to meet the insurance requirements as set forth above.

- 16. **Participant Waiver and Release Forms:** To the extent that Grantee requires Participants in its programs or others who use the Mini Pitch to sign waiver and release forms, Grantee shall include the Foundation and the Foundation Parties as released parties in the form.
- 17. **Use of Mark:** Notwithstanding anything in this Agreement to the contrary, in the event Grantee desires to use a Mark owned or controlled by Foundation in a manner consistent with this Agreement, Grantee shall first submit a sample of the concept of the proposed use to Foundation for prior written approval, which approval may be withheld in the sole discretion of Foundation. Any such use by Grantee shall create no rights for Grantee in or to the Mark. Each Mark shall remain at all times the sole and exclusive intellectual property of Foundation, and Foundation shall have the right, from time to time, to request samples of use from which it may determine compliance with these terms and conditions. Notwithstanding any provision of this Agreement to the contrary, Foundation reserves, in its sole and absolute discretion, the right to prohibit use of its Marks.
- 18. **Applicable Law; Jurisdiction:** This Agreement shall be governed by and construed in accordance with the laws of the Georgia,. Each party agrees that any action or proceeding with respect to this Agreement

may only be brought in a federal or state court situated in the State of Georgia, and by execution and delivery of this Agreement, such party irrevocably consents to jurisdiction and venue in each such court.

- 19. **Third Party Beneficiaries:** It is expressly agreed and by this statement specifically intended by the parties that nothing within this Agreement shall be construed as indicating any intent by either party to benefit any other entity or person not a party signatory to this Agreement by any provision or to entitle any such third party to any right of action on account hereof.
- 20. **Notices:** Any notices given under this Agreement must be made in writing (a) if to Foundation, at the address of Foundation as provided or at such other address as Foundation may designate, or (b) if to Grantee, at the address of Grantee provided or at such other address as Grantee may designate.
- 21. **Entire Agreement; Modifications:** This Agreement contains the entire agreement between Foundation and Grantee and cannot be changed, modified, amended, waived or canceled except by an agreement in writing and executed by each of the parties hereto.
- 22. **Counterparts and Facsimile Signatures:** This Agreement may be executed in one or more counterparts each of which shall be deemed an original but all of which together shall constitute the same instrument. This Agreement may be executed by facsimile signature by any party and such signature will be deemed binding for all purposes hereof without delivery of an original signature being thereafter required.

*[Remainder of page intentionally left blank]*

IN WITNESS WHEREOF, the parties have executed this Agreement by their duly authorized signatories as of the date first above written.

**U.S. Soccer Foundation**

**City of Hapeville**

By: \_\_\_\_\_

By: \_\_\_\_\_

Name: Rob Kaler

Name: \_\_\_\_\_

Title: COO & General Counsel

Title: \_\_\_\_\_

Date: \_\_\_\_\_

Date: \_\_\_\_\_

ATTACHMENT A

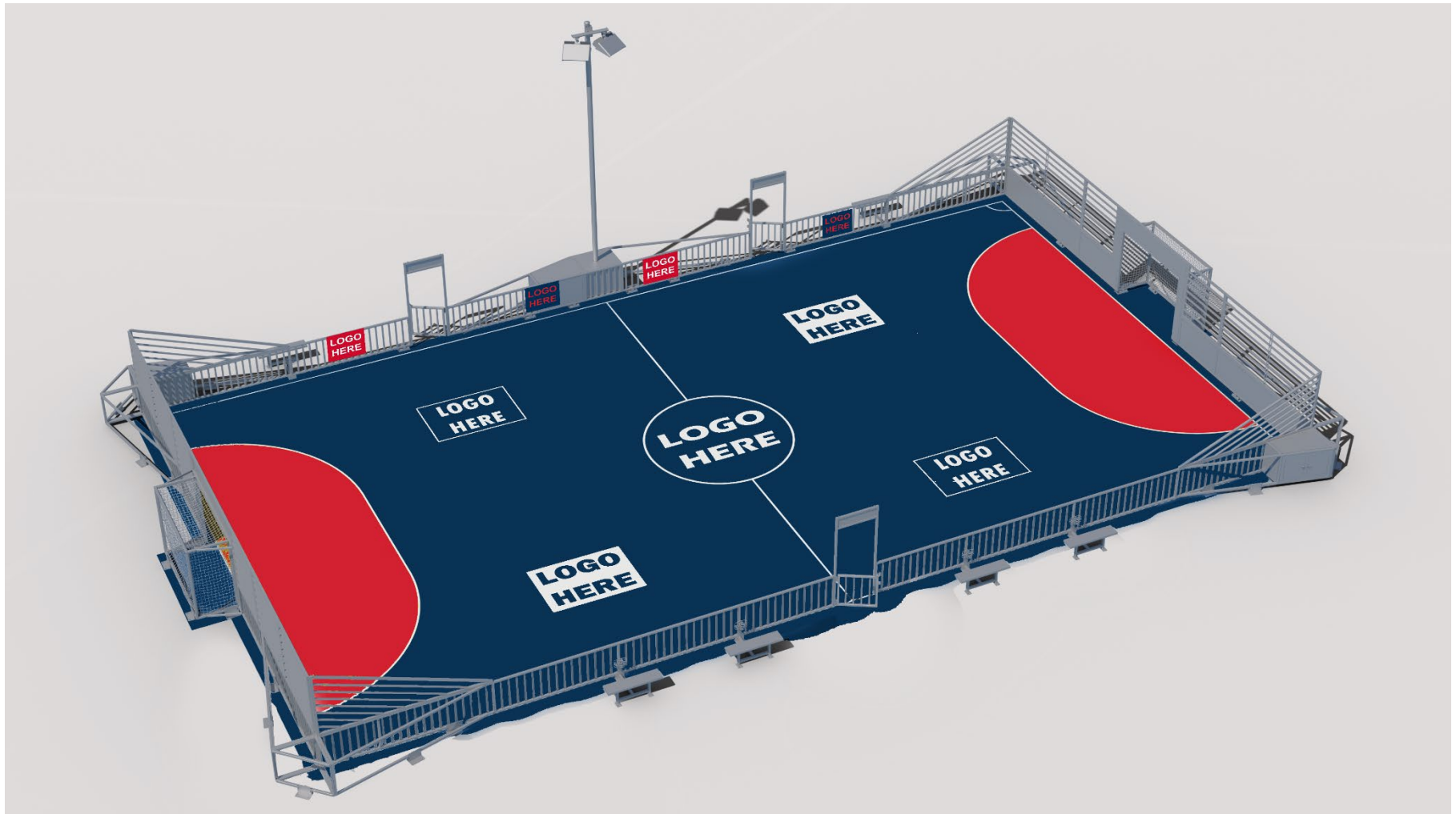

# Mini-Pitch System™

MODULAR SPORTS SOLUTION



*The Mini-Pitch System™ modular sports solution has an innovative, all-in-one design to help communities create fun and active play spaces by revitalizing public areas.*

Created to assist the U.S. Soccer Foundation in providing safer places to play the game, the Mini-Pitch System is ideal for transforming abandoned courts and other underutilized areas into places where children and families can come together in the spirit of teamwork, empowerment, and physical activity. The system supports the Foundation's *It's Everyone's Game* movement to ensure that all children have access to the game and its many benefits.

#### **Complete**

The mini-pitch comes as a modular system complete with lighting, fencing, goals, benches, ADA-compliant access, and lockable storage.

#### **Convenient**

Assembly can be done by a three-person crew in approximately 16 hours.

#### **Customizable**

You'll have options on the size of your pitch and custom signage. Tile surfacing is provided and can be color customized.



## Complete System

The Mini-Pitch System™ modular sports solution includes lighting, structural, and electrical components designed and engineered to work together for streamlined installation and reliable operation.

- Factory-built, wired, aimed, and tested.
- Fast, trouble-free installation.
- Rugged reliability, designed to be long-lasting in all weather conditions and atop all surfaces.
- 10-year warranty covers all parts and labor.

## TLC for LED® Lighting

Enjoy the benefits of the LED sports lighting technology of choice at venues around the world.

- Custom optics create a more uniform distribution of light for better visibility.
- Patented glare control preserves darkness around your pitch, keeping neighbors happy.
- Instant on/off and energy efficient operation.

## Control-Link® Service

Your system will be supported by Musco's Control-Link control system.

- Manage your lights instantly, from anywhere, with a touch of a smartphone.
- 24/7 support from the Musco Team includes troubleshooting and scheduling assistance.
- Get a real, live voice on the other end of the phone anytime you call Control-Link Central™ service center.

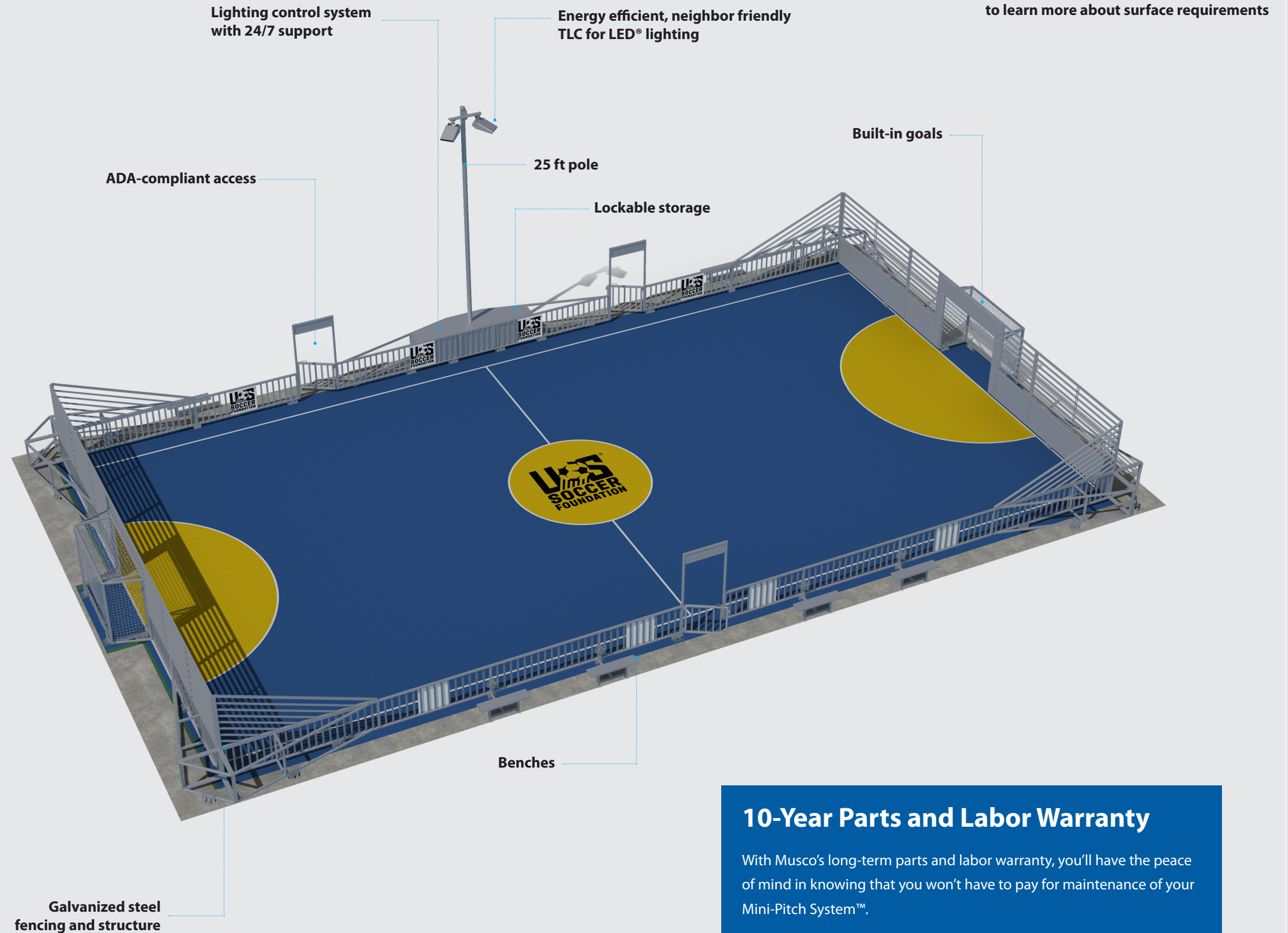

## 10-Year Parts and Labor Warranty

With Musco's long-term parts and labor warranty, you'll have the peace of mind in knowing that you won't have to pay for maintenance of your Mini-Pitch System™.

- No maintenance costs for the next decade.
- Every part and all labor covered.
- Supported by Musco's regionally-based technicians.

*Separate playing surface warranty is provided by the surface vendor*

# Your Pitch, Your Way

The Mini-Pitch System™ modular sports solution gives you customization options with the ability to combine any of the below widths and lengths to meet your exact needs. *Measurements provided are the exterior dimensions of the structure.*

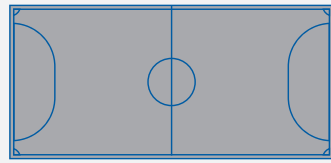

40 ft x 84 ft  
12 m x 25 m

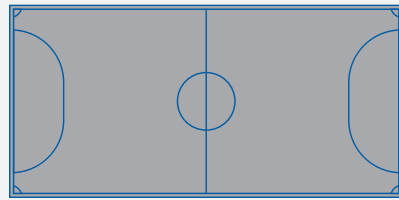

50 ft x 104 ft  
15 m x 32 m

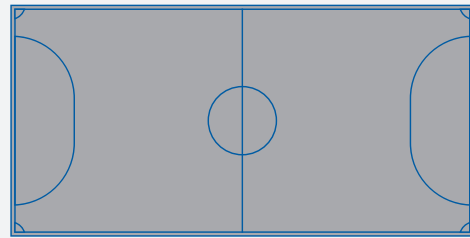

60 ft x 120 ft  
18 m x 36 m

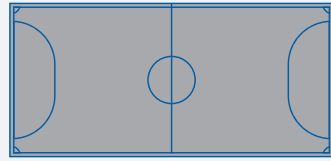

76 ft x 84 ft  
23 m x 25 m

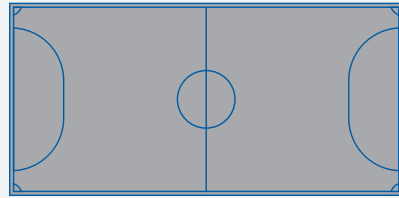

96 ft x 104 ft  
29 m x 32 m

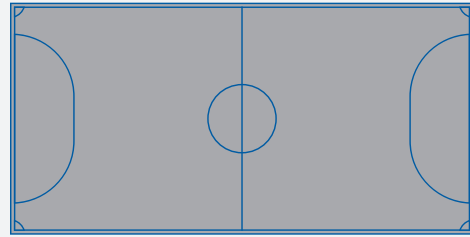

116 ft x 120 ft  
35 m x 36 m

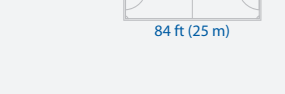
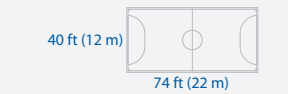
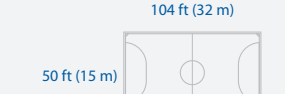
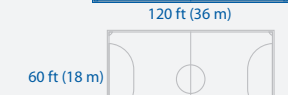
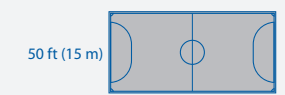
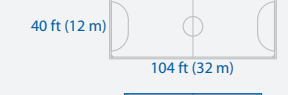
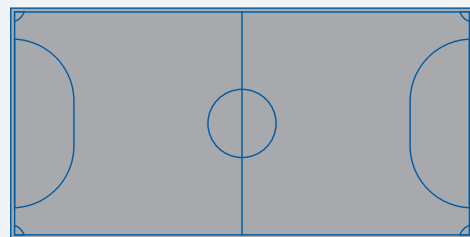

West Side High School, Newark, New Jersey, USA



Hollywood PAL Mini-Pitch - Hollywood, Florida, USA

Birdland Mini-Pitch, Des Moines, Iowa, USA



Evans Middle School, Ottumwa, Iowa, USA



We Make It Happen.

[www.musco.com](http://www.musco.com)  
e-mail: [lighting@musco.com](mailto:lighting@musco.com)



[www.usoccerfoundation.org](http://www.usoccerfoundation.org)  
e-mail: [info@usoccerfoundation.org](mailto:info@usoccerfoundation.org)

©2021, 2024 Musco Sports Lighting LLC - M-5056-enUS-8  
U.S. and foreign patents issued and pending.

US Soccer Foundation is a registered trademark in the United States to United States Soccer Foundation.

# Mini-Pitch: Identify Your Site!

A mini-pitch is a customized, hard court soccer space suited for communities where space is at a premium. To address the lack of access to soccer facilities for structured programming and free play, our Safe Places to Play program transforms underutilized spaces into these state-of-the-art soccer mini-pitches. The brightly colored spaces also transform the look and feel of neighborhoods.

Examples of existing sites have included schoolyards, tennis courts, basketball courts, and parking lots.

BEFORE



AFTER



## Existing Site Requirements

- Asphalt or concrete surface
- Surface dimensions of 45ft x 80ft or greater
- Surface does not have substantial defects (i.e. wide cracks, heaving, potholes) or other obstacles (i.e. drains, permanent walls).
- Surface is accessible by a telehandler or forklift for installation (or fence can be temporarily removed so this can occur).
- No planned renovations to the site for at least 6 years



# Mini-Pitch System Lighting



The structure includes a light pole with 2 LED lighting fixtures.

- Two circuits must be brought to a single point on the mini-pitch: 1) a 120v control circuit and 2) a lighting circuit. The lighting circuit needs a minimum of 208v single phase, but other options are available.
- Connection point can be in the middle of either sideline.
- 120v control circuit allows the lights to operate and be scheduled. The circuit draws less than an amp. A control transformer can be utilized in certain applications.
- The lighting circuit can be 208v, 240v, or 347v. The draw on the lighting circuit depends on the voltage (see table below – values are for a single fixture). All lighting circuits are single phase.

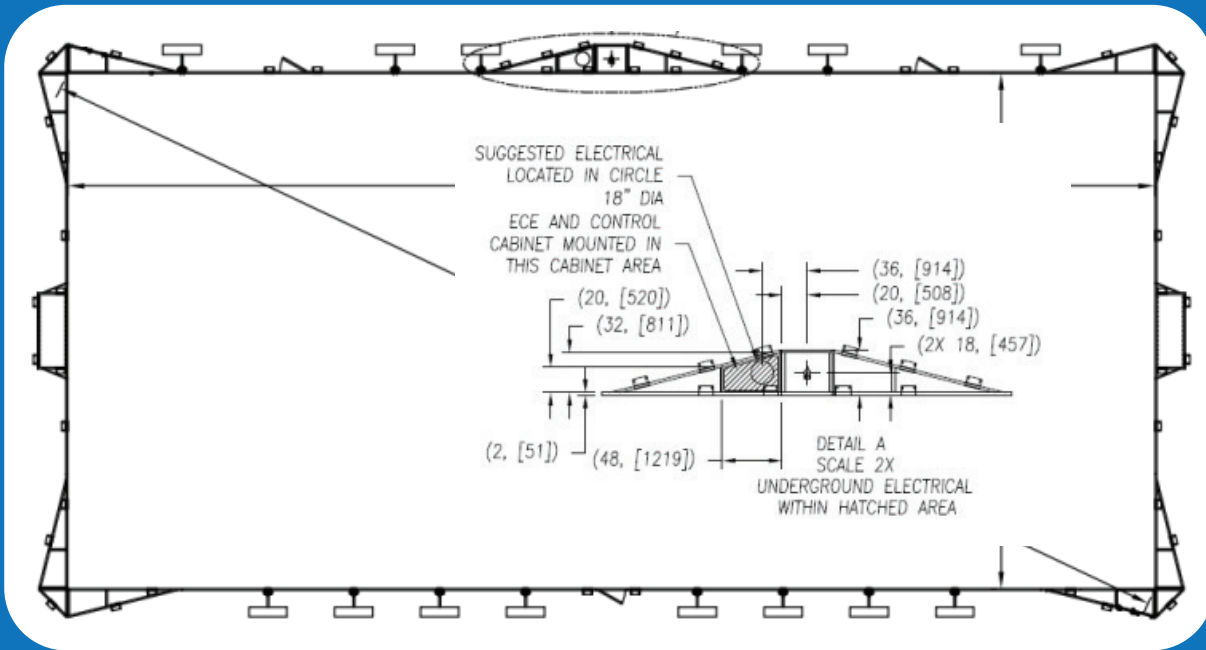

	200 Vac 50/60 Hz	208 Vac 60 Hz	220 Vac 50/60 Hz	230 Vac 50 Hz	240 Vac 50/60 Hz	277 Vac 60 Hz	347 Vac 60 Hz	380 Vac 50/60 Hz	400 Vac 50 Hz	415 Vac 50 Hz	480 Vac 60 Hz
Max operating current per luminaire <sup>2</sup>	3.32 A	3.19 A	3.02 A	2.89 A	2.77 A	2.40 A	1.92 A	1.75 A	1.66 A	1.60 A	1.39 A

For more information about mini-pitches and other *Safe Places to Play* initiatives, contact **Alex Bard** at [abard@ussoccerfoundation.org](mailto:abard@ussoccerfoundation.org)



If you are ready to submit a mini-pitch site for review, please **click here**.



## PROPOSAL

**TO THE:**

Hapeville Fire Dept. (Sourcewell Account # 29544)  
Attn: Chief Condrey  
3468 N Fulton Ave  
Hapeville, Georgia 30354

**DATE:** January 16, 2026

We hereby propose and agree to furnish the following firefighting equipment upon your acceptance of this Proposal:

**One (1) Sutphen Heavy Duty 75' Rear Mount Aerial Ladder (SLR75), complete with all specified loose equipment, furnished and delivered for a total lump sum of ..... \$1,885,768.56**

***If you elect to take the 100% prepayment discount within 30 days of receipt of contract or purchase order, the final contract amount will be \$1,747,478.87.***

***Proposal via the Sourcewell Co-Operative Purchase Agreement Contract #113021-SUT***

The apparatus and equipment being purchased hereunder shall be completed within approximately 23 - 25 months after the Sutphen's receipt and approval of Purchaser's acceptance of this Proposal.

This Proposal shall be valid for thirty (30) days. If a Purchase Agreement or Purchase Order is not received by Sutphen within 30 days of the date of this Proposal, Sutphen reserves the right to extend, withdraw, or modify this Proposal, including pricing, delivery times, and prepayment discounts, as applicable.

Respectfully submitted,

*Todd Moore*

Todd Moore  
Authorized Representative for Sutphen Corporation

## TERMS & CONDITIONS

Evolving industry conditions and market volatility may materially impact the cost to manufacture fire apparatus. As such, Sutphen reserves the right to impose a price adjustment. The price adjustment will be determined using the Producer Price Index (PPI) – specifically, WPU141106843 the Commodity Data for Heavy Duty Truck Manufacturing: Buses, including military and firefighting vehicles with chassis of own manufacture. The calculation will be based on the PPI value the month of contract execution, compared to the PPI value 12 months prior to the originally slotted production completion date.

If the PPI reflects an increase exceeding 5% over this period, the Purchaser will be subject to a price adjustment equal to the percentage increase in excess of 5%. Sutphen will provide written notice to the Purchaser as soon as it reasonably anticipates the need to apply such adjustment. Upon receipt of such notice, the Purchaser may request to terminate the Agreement; however, acceptance of such termination shall be at Sutphen's sole and absolute discretion. If the termination request is approved, a cancellation fee equal to 5% of the original contract purchase price will be applied.

Sutphen will use its reasonable best efforts to deliver the apparatus within the timeframe quoted herein, provided that such delivery date shall be automatically extended for delays beyond Sutphen's control, including, without limitation, strikes, labor disputes, riots, civil unrest, pandemics, war or other military actions, sabotage, government regulations or controls, fire or other casualty, or inability to obtain materials or services. If such delay occurs, Sutphen shall give notice of delay to Purchaser. Purchaser shall not be entitled to any discount or reduction in price for such delay and Sutphen shall not be liable for any damages (compensatory, incidental, consequential or otherwise) related to such delay.

Payment must be processed within 48 hours after the truck has been received by the dealer for pre-delivery inspection. Should payment be delayed, Sutphen reserves the right to charge interest at the rate of one and one-half percent (1.5%) per month, beginning on the day after payment is due.

Transfer of the Manufacturer's Certificate of Origin (MCO) shall take place during pre-delivery inspection, and upon payment in full in accordance with these terms. Sutphen reserves the right to withhold delivery of the MCO until payment in full is received. If Purchaser requires any third-party equipment mounting, the apparatus shall be moved to the third-party facility by the dealer or Purchaser for such mounting. Such third-party work shall not delay or offset payment to Sutphen. The apparatus shall be tested per NFPA #1900 at Sutphen's manufacturing facility. Purchaser agrees that the apparatus and equipment being purchased hereunder shall not be driven or used in any manner until it is paid for in full. In the event there are any shortages or omissions with the apparatus at time of completion, Purchaser may withhold a sum equivalent to the price of any such shortages as determined by Sutphen.

In the case of any default in payment hereunder or in the payment on any notes, negotiable paper, obligations or other instruments issued by Purchaser, Sutphen may take full possession of the apparatus and equipment or of the piece or pieces upon which default has been made, and any payments that have been made theretofore shall be applied as rent in full for the use of the apparatus and equipment up to the date of taking possession by Sutphen.

Sutphen warrants to Purchaser that all goods and services furnished hereunder will conform in all respects to the terms of this order, including any applicable change orders, drawings, specifications, or standards incorporated herein, and/or shall be free of defects in materials, workmanship, and free from such defects in design. In addition, Sutphen warrants that the goods and services are suitable for and will perform in accordance with the purposes for which they were intended, for a period of one year from the Warranty Registration Date, unless an extended warranty is purchased.

The purchase price provided for herein does not include any federal, state or local sales tax, duties, imposts, revenues, excise or other taxes which may hereafter be imposed by governmental authority or otherwise and which are made applicable to the apparatus or equipment covered by this Proposal. In the event that any such taxes are subsequently imposed and become applicable, the purchase price herein shall be increased by the amount of such taxes and such sum shall be immediately paid by Purchaser to Sutphen. To the extent applicable, the prices and deliveries set forth herein are subject to the Defense Production Act.

Sutphen shall provide insurance insuring the apparatus and equipment against loss by fire, theft, or collision and insuring against property damage and personal injury through the completion of the apparatus and transfer of the Manufacturer's Certificate of Origin.

After the execution of this Agreement, Purchaser shall have no right to terminate the Agreement. Sutphen may, in its absolute and sole discretion, accept Purchaser's request to terminate the Agreement. In the event Sutphen accepts Purchaser's request to terminate the Agreement, Sutphen may charge a cancellation fee. The following charge schedule based on costs incurred may be applied, at Sutphen's sole discretion: (a) 10% after order is accepted by Sutphen; (b) 30% of the Purchase Price after production has commenced. The cancellation fee may increase accordingly as costs are incurred as the order progresses through engineering and into manufacturing.

These Terms and Conditions ("T&C") contained in the Proposal provided herein take precedence over all previous negotiations, oral or written, and no representations or warranties are applicable except as specifically contained in these or in any subsequently signed agreement between the Parties. No waiver of any of the provisions of these T&C shall be deemed a waiver of any other provision, whether similar, nor shall any waiver constitute a continuing waiver. If a Purchase Order is issued, this Proposal, including the Terms and Conditions contained herein, shall supersede the terms in the Purchase Order where terms may be inconsistent.

This Proposal shall be governed and controlled as to interpretation, enforcement, validity, construction, effect and in all other respects by the laws, statutes, and decisions of the State of Ohio. Exclusive jurisdiction and venue for any litigation at all related to this in the Franklin County Court of Common Pleas, Columbus, Ohio, and the parties hereto consent and submit to the general jurisdiction of this court. All of these T&C shall be binding upon and inure to the benefit of and be enforceable by Sutphen, Purchaser, their successors and assigns.



**FAMILY OWNED  
SINCE 1890**

**Prepayment Discount Options  
For The  
Hapeville Fire Department  
SLR75  
1/16/2026**

Current Proposal Price **\$1,885,768.56**

Option 1 25%	For a prepayment in the amount of \$471,442.14 the discount would be \$34,572.42 for a total selling price of . . . .	\$1,851,196.14
Option 2 50%	For a prepayment in the amount of \$942,884.28 the discount would be \$69,144.85 for a total selling price of . . . .	\$1,816,623.71
Option 3 75%	For a prepayment in the amount of \$1,414,326.42 the discount would be \$103,717.27 for a total selling price of . . . .	\$1,782,051.29
Option 4 100%	For a full prepayment, we offer a discount of \$138,289.69 for a final selling price of . . . . .	\$1,747,478.87

**NOTE:** For any option above, the prepayment would be due within 30 days of contract signing in order to receive the discounts listed. Any remaining balance would be due at the time of delivery.

**Sutphen Corporation**  
PO Box 158 • Amlin, OH 43002-0158  
6450 Eiterman Road • Dublin, OH 43016-8711  
**Tel 614 889-1005 • Toll Free 800 848-5860 • Fax 614 889-0874**  
**www.sutphen.com • Sutphen@sutphencorp.com**

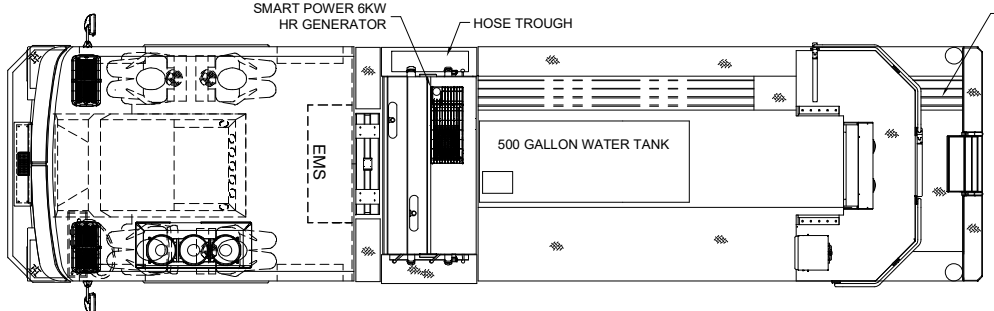
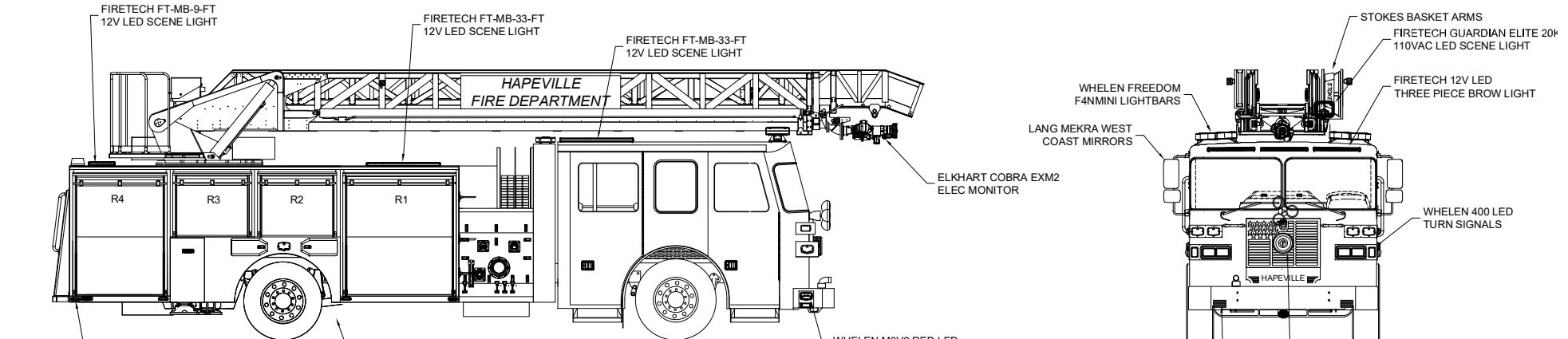

COMPT	DOORS	OPENING DIMENSIONS	INSIDE DIMENSIONS	VOLUME
L1 UPPER	ROLL-UP	55.50"W x 28.00"H	62.12"W x 37.13"H x 10.00"D	13.34 CU. FT.
L1 LOWER	ROLL-UP	55.50"W x 30.00"H	62.12"W x 30.00"H x 23.93"D	25.80 CU. FT.
L2	ROLL-UP	38.00"W x 27.13"H	44.50"W x 36.25"H x 10.00"D	9.33 CU. FT.
L3	ROLL-UP	38.00"W x 27.13"H	44.50"W x 36.25"H x 10.00"D	9.33 CU. FT.
L4 UPPER	ROLL-UP	46.00"W x 28.00"H	50.06"W x 37.13"H x 10.00"D	10.75 CU. FT.
L4 LOWER	ROLL-UP	46.00"W x 30.00"H	50.06"W x 30.00"H x 23.93"D	20.80 CU. FT.
R1 UPPER	ROLL-UP	55.50"W x 28.00"H	62.12"W x 37.13"H x 10.00"D	13.34 CU. FT.
R1 LOWER	ROLL-UP	55.50"W x 30.00"H	62.12"W x 30.00"H x 23.93"D	25.80 CU. FT.
R2	ROLL-UP	38.00"W x 27.13"H	44.50"W x 36.25"H x 10.00"D	9.33 CU. FT.
R3	ROLL-UP	38.00"W x 27.13"H	44.50"W x 36.25"H x 10.00"D	9.33 CU. FT.
R4 UPPER	ROLL-UP	46.00"W x 28.00"H	50.06"W x 37.13"H x 10.00"D	10.75 CU. FT.
R4 LOWER	ROLL-UP	46.00"W x 30.00"H	50.06"W x 30.00"H x 23.93"D	20.80 CU. FT.
TOTAL VOLUME				178.70 CU. FT.

DUO SAFETY LADDER COMPLIMENT 10' FOLDING 16' ROOF 24' 2-SECTION 35' 3-SECTION

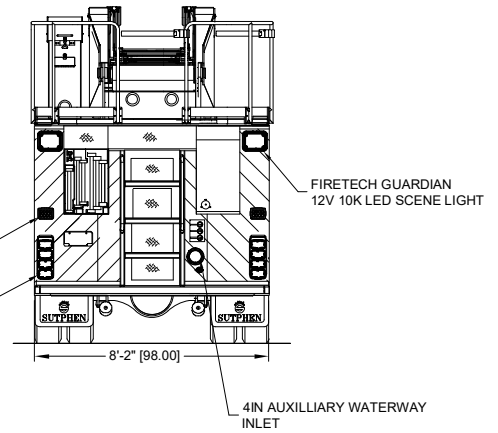
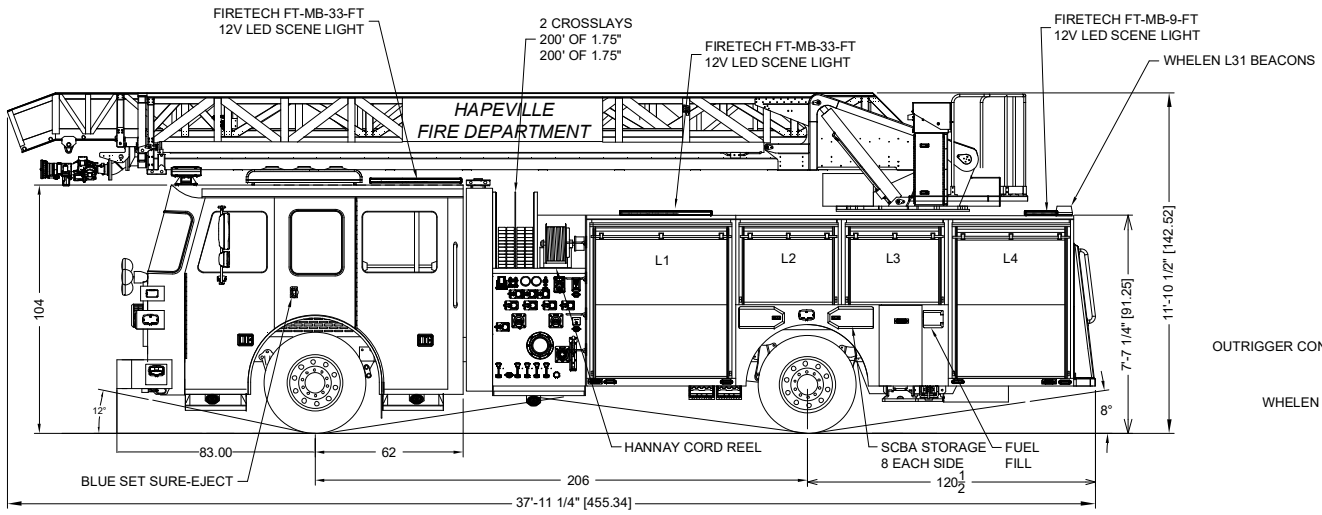

DIMENSIONS SHOWN ON THIS DRAWING ARE APPROXIMATE AND ARE SUBJECT TO MINOR DEVIATIONS DURING CONSTRUCTION.	CUSTOMER APPROVAL				DRAWN BY: S.J.G.	DATE: 11-5-2025	MFG. FACILITY: HILLIARD		
	NAME:								
IN THE EVENT OF A DISCREPANCY BETWEEN THE SUTPHEN SPECIFICATIONS AND DRAWING, THE SUTPHEN SPECIFICATIONS SHALL PREVAIL.	TITLE:							HAPEVILLE FIRE DEPARTMENT HAPEVILLE, GA	
DRAWING IS FOR REFERENCE ONLY. SOME ITEMS PROPOSED MAY NOT BE SHOWN OR NOTED.	DATE:				REV.	DESCRIPTION	BY	DATE	SLR75 HS-XXXX

THIS PRINT IS PROVIDED ON A RESTRICTED BASIS AND IS NOT TO BE USED IN ANY WAY DETRIMENTAL TO THE INTEREST OF SUTPHEN CORPORATION.



**Sutphen**  
**Component Report**  
 Dealership: Williams Fire  
 Apparatus\_3 (Moore)

**HS- Hapeville Fire Department, Georgia**  
**SLR75 Aerial Ladder**

Order#: DQ018816-1  
 Contact: Nicholas Condrey  
 Position: Fire Chief  
 Phone: 404-669-2167  
 Mobile:  
 Email: Ncondrey@hapeville.org

Bill To	Ship To
Customer: Hapeville Fire Department Contact: Nicholas Condrey, Fire Chief Address: 3468 N Fulton Ave Hapeville, Georgia 30354	Customer: Hapeville Fire Department Contact: Nicholas Condrey, Fire Chief Address: 3468 N Fulton Ave Hapeville, Georgia 30354

Comments
Project Manager: Sales Person: Todd Moore Revision Level: Truck Type: Body Facility:

Quote Line Number 1

Line	Item #	Qty	Item Description/Comments
1	10000225	1	STD WIRING SCHEMATIC (USB)
<b>CHASSIS</b>			
2	10010006	1	CHASSIS, CUSTOM
3	51070206	1	WHEELBASE = 206
4	25010255	1	FRAME, 10" DOUBLE RAILS, DOMEX, SINGLE AXLE (110K PSI)
5	45040100	1	FRONT BUMPER CLIP
6	45010001	1	FRONT TOW EYES, BELOW BUMPER, PAINTED
7	46010000	1	REAR TOW EYES, PAINTED
8	40010250	1	STEERING - ROSS TAS-85
9	40010500	1	STEERING GEAR WARRANTY, ROSS, 1-YEAR
10	22010050	1	DRIVE LINE, SPICER, 1810 SERIES
11	23015100	1	ENGINE, CUMMINS X10 HHD 450HP DOC-DPF-DEF-SCR OBD
12	23029200	1	ENGINE WARRANTY, 5 YEAR, 100,000 MILES FOR CUMMINS (X SERIES)
13	23029400	1	AFTERTREATMENT WARRANTY, 5 YEAR, 100,000 MILES FOR CUMMINS (X SERIES)

Line	Item #	Qty	Item Description/Comments
14	23030006	1	AIR INTAKE/EMBER SEPARATOR
15	23031176	1	FUEL FILTER/WATER SEPARATOR, PRIMARY, FLEETGUARD FUEL PRO FH230
16	23031220	1	FUEL FILTER, SECONDARY, FLEETGUARD, FF5825NN
17	47012520	1	TRANSMISSION, ALLISON GEN 6, EVS4000 (X10HHD, X12, X15)
18	47020100	1	TRANSMISSION WARRANTY, ALLISON, 5 YEARS
19	23110000	1	JACOBS ENGINE BRAKE
20	47024050	1	TRANSMISSION COOLER
21	47030000	1	ALLISON TOUCH PAD SHIFTER
22	47030120	1	SHIFTER PAD GEARING, 6 GEARS OPEN, MODE BUTTON FOR GENERATOR
23	21021200	1	COOLING SYSTEM
24	21030195	1	COOLANT FILTER
25	21030000	1	FAN CLUTCH
26	21030200	1	RADIATOR COOLANT RECOVERY, PRESSURIZED SYST
27	26010000	1	FUEL TANK, STEEL, 65 GALLON
28	26030000	1	FUEL FILL
29	26030100	1	FUEL COOLER
30	24040000	1	DIESEL EXHAUST FLUID TANK
31	13010225	1	ALTERNATOR, LEECE NEVILLE 420 AMP BLP4003
32	13030100	1	LOW VOLTAGE ALARM, FLOYD BELL TXB-V86-515-QF
33	15010500	1	BATTERIES, INTERSTATE TYPE 31 MHD (4)
34	15031700	1	BATTERY JUMPER TERMINALS
35	15031510	1	BATTERY CHARGER, KUSSMAUL CHIEF 4012
36	15030465	1	120V SHORELINE INLET, KUSSMAUL SUPER 20 AUTO EJECT W/ OLED DISPLAY 091-55-266-XX
37	15040100	4	120V OUTLET WIRED TO SHORELINE INLET - EA (4)
38	14022130	1	FRONT AXLE, HENDRICKSON STEERTEK NXT 23,000 LB.
39	14030120	1	FRONT AXLE WARRANTY, HENDRICKSON, 5 YEARS

Line	Item #	Qty	Item Description/Comments
40	41022130	1	FRONT SUSPENSION, HENDRICKSON 23,000 LBS. (4) 56" LEAFS
41	41030035	1	FRONT SUSPENSION WARRANTY, HENDRICKSON, 3 YEARS (PAIRED W/HENDRICKSON REAR SUSPENSION)
42	41040510	1	STEER ASSIST
43	43010322	1	FRONT TIRES, GOODYEAR, 425/65R22.5 LRL, ARMOR MAX PRO GRADE MSA 22.5 X 12.25 WHEELS
44	14510545	1	REAR AXLE, MERITOR RS-35-185 35,000 LB.
45	14530010	1	REAR AXLE WARRANTY, MERITOR, 3 YEARS
46	14530150	1	TOP SPEED, 60 MPH
47	42010650	1	REAR SUSPENSION, HENDRICKSON ROADMAAX, 35,000 LBS. AIR RIDE
48	42030035	1	REAR SUSPENSION WARRANTY, HENDRICKSON, 3 YEARS (PAIRED W/HENDRICKSON FRONT SUSPENSION)
49	44010400	1	REAR TIRES, GOODYEAR 315/80R22.5X 9, LRL G289 WHA HGWY, 35,000 GVWR
50	42910300	1	TIRE PRESSURE MONITOR, QUICK PRESSURE
51	44215100	1	WHEELS, ALUM, ACCURIDE (max 35K rear)
52	44270100	1	HUB COVERS, FRONT & REAR, POLISHED STS (Single Axle)
53	44270300	1	CHROME LUG NUT CAPS, FRONT & REAR (Single Axle)
54	44271100	1	MUD FLAPS, FRONT (PAIR)
55	44271200	1	MUD FLAPS, REAR (PAIR)
56	16010220	1	BRAKES MERITOR SCAM 6" FRONT, SCAM 8.625" REAR (SINGLE AXLE)
57	18030400	1	FRONT WHEEL BRAKE ASSIST FOR FOUR WHEEL BRAKE SERVICE
58	18010043	1	AIR BRAKE SYSTEM 5 TANKS WABCO 1200 DRYER (31K, 35K)
59	18015000	1	WABCO ABS BRAKING SYSTEM WARRANTY, 3 YEARS /300,000 MILES
60	18030010	1	AIR BRAKE RELEASE VALVE, WABCO
61	18020000	1	CENTRAL LOCATION FOR AIR TANK DRAINS
62	18030140	1	AIR INLET CONNECTION W/CHECK VALVE
63	18035110	1	AIR COMPRESSOR, KUSSMAUL AUTO PUMP AC, 100PSI
64	18036105	1	TIMER, KUSSMAUL AUTO PUMP
65	18210000	1	ELEC STABILITY CONTROL SYST

Line	Item #	Qty	Item Description/Comments
66	18110075	1	WABCO 5 CHANNEL ANTI-LOCK BRAKES W/ASR (31K, 35K)
67	14530510	1	TIRE CHAINS, RUDD, 6 STRANDS
68	53510000	1	COMPRESSION FITTINGS ON AIR SYSTEM (CHASSIS)
69	54010000	1	MISCELLANEOUS ITEMS ON CHASSIS
70	54010010	1	DATA, SAFETY & WARNING TAGS APPLICATION, ADHESIVE
71	54010100	1	AERIAL CHASSIS PREP (SINGLE AXLE)
<b>CAB</b>			
72	11023291	1	CAB TSAL4J 62" FLAT
73	11030025	1	CAB CERTIFICATION - STRUCTURAL INTEGRITY
74	11030960	1	CAB LOCKDOWN LATCHES W/INTERLOCK & INDICATOR LIGHT
75	11031025	1	CAB TILT SYSTEM, AIR CONTROL VALVE
76	11031030	1	CAB TILT CONTROL LOCATION, OFFICER'S SIDE PUMP PANEL
77	11031100	1	MANUAL BACK-UP TILT SYSTEM
78	11031350	1	CAB DOORS, FULL LENGTH (4)
79	11031385	1	CAB STEPS, LOWER GRIP STRUT, INTERMEDIATE DIAMONDPLATE
80	11031390	1	AUXILIARY CAB STEPS, ALUM, GRIP STRUT (SET OF 4)
81	11031399	1	CAB STEP LIGHTING, TECNIQ E45 LED STRIP LIGHTS
82	11031421	1	CAB DOOR WINDOWS, POWER (4)
83	11031401	1	CAB SIDE WINDOWS, FIXED, BOTH SIDES
84	11031450	1	TWO SLIDING WINDOWS IN BACK WALL OF CAB APPROX 16.25" X 14.25"
85	11031465	1	WINDOW TINTING (LIMO TINT 8%) - EACH (6)
86	52010010	1	ELECTRIC INTERMITTENT WIPERS
87	52030100	1	DEACTIVATE WINDSHIELD WIPERS WITH PARKING BRAKE ENGAGED
88	52030200	1	WINDSHIELD WASHER RESERVOIR
89	38010015	1	MIRRORS LANG MEKRA 300 SERIES REMOTE
90	11024420	1	UPPER GRILLE, AMERICAN FLAG LEVEL STYLE FACADE (X SERIES)
91	11024510	1	FLAMING "S" LOGO, UPPER GRILLE, ILLUMINATED

Line	Item #	Qty	Item Description/Comments
92	11024615	1	LOWER GRILLE, POLISHED STAINLESS, LASER CUT LETTERING W/ BACKLIGHTING
93	20012200	1	BUMPER, 12" FORMED STEEL CHANNEL, PAINTED
94	20029830	1	BUMPER SIDES, PAINTED STEEL, W/POCKET (12-24" EXTENSION)
95	20029910	1	BUMPER ANGLES, PAINTED STEEL, FLAT (12-30" EXTENSION)
96	20042140	1	PROTECTIVE BUMPER COATING, RAPTOR, TOP EDGE OF FRONT BUMPER
97	12010500	1	AIR HORNS, DUAL, GROVER #2040 RECTANGULAR, BEHIND PERFORATION
98	12030015	1	AIR HORNS CUTOUTS IN BUMPER, BEHIND PERFORATIONS (X SERIES)
99	12030305	1	FOOT SWITCH, DRIVER'S SIDE
100	12040010	1	MOMENTARY SWITCH ON DASH, OFFICER'S SIDE
101	12510109	1	ELEC SIREN, WHELEN 295HFSA7, REMOTE FLUSH MOUNT WITH REMOVABLE MIC
102	12530205	1	ELEC SIREN WIRED TO STEERING WHEEL BUTTON
103	12620200	1	SIREN SPEAKER, 100W, WHELEN, SA314B, BLACK FINISH
104	12670110	1	SIREN SPEAKER(S) INSTALLED BEHIND CAB GRILLE
105	12710100	1	SIREN, FEDERAL Q2B, GRILLE MOUNT
106	12730305	1	FOOT SWITCH, DRIVER'S SIDE, FOR MECH SIREN
107	12730350	1	MOMENTARY SWITCH ON DASH, OFFICER'S SIDE, FOR MECH SIREN
108	12730363	1	SIREN BRAKE SWITCH FOR MECH SIREN, DRIVER'S & OFFICER'S SIDE
109	12730400	1	MASTER SHUT OFF SWITCH WITH GUARD FOR Q2B
110	32520520	1	HEADLIGHTS, LED, FIRETECH FT-4X6, DUAL STS HOUSINGS (MIXED UPPER WARNING & TURN SIGNAL)
111	32530500	1	ALTERNATING FLASHER FOR HEADLIGHT
112	48010300	1	FRONT TURN SIGNALS, WHELEN 400 SERIES LED (4) (MIXED HOUSING)
113	32530640	1	CORNERING LIGHTS, WHELEN M6V2 LED
114	32530754	1	ICC, LED BROW LIGHT INTEGRATED MARKERS
115	27022120	1	HANDRAILS, CAB EXTERIOR, KNURLED STAINLESS STEEL (4) SIDE
116	27030615	1	COAT HOOKS ON UPPER GRAB HANDRAILS, DRIVER'S SIDE (2)
117	27030655	1	COAT HOOKS ON UPPER GRAB HANDRAILS, OFFICER'S SIDE (2)

Line	Item #	Qty	Item Description/Comments
118	27030710	1	HANDRAILS, FRONT OF CAB, KNURLED STAINLESS STEEL (PAIR)
119	27025000	1	HANDRAILS, CAB INTERIOR, BLACK RUBBER COATED (2) FRONT ENTRY
120	27030120	1	HANDRAILS, REAR CAB INTERIOR DOOR, BLACK RUBBERIZED (2) AND KNURLED STS AT WINDOW (2)
121	27040110	1	INTERIOR DOOR, NYLON STRAP (FRONT CAB DOORS)
122	11035422	1	DIAMONDPLATE CAB ROOF 56" x FULL WIDTH
123	11033202	1	3/16" SMOOTH ALUM BACK WALL & SIDE WALLS, INSIDE CAB
124	31010285	1	INTERIOR, MULTISPEC BLACK SPECKLE PAINT W/GRAY-BLACK DURAWEAR
125	11032929	1	DOOR PANEL, FULL STS
126	31010291	1	CAB INTERIOR FLOOR COVERING, BLACK RUBBERIZED
127	22510100	1	ENGINE ENCLOSURE, FULL LENGTH
128	22510530	1	ENGINE ENCLOSURE COVERING, SCORPION BLACK URETHANE BLEND
129	11031677	1	CENTER CONSOLE NOT PROVIDED
130	22610050	1	ENGINE HOOD LIGHT, LED (1)
131	11031510	1	FLAT WORK SURFACE IN LIEU OF GLOVE BOX
132	29810100	1	CHASSIS ELECTRICAL DESCRIPTION
133	30010135	1	INSTRUMENTATION, AMETEK W/ CENTER & OVERHEAD CONSOLES (AERIALS)
134	30010508	1	LOWER COMMAND CONSOLE, X10
135	30010610	1	CAB PUMP SHIFTER, ELECTRIC W/ROUND KNOB (FOR HALE G-SERIES PUMP TRANSMISSION)
136	30011000	1	PUMP INTERLOCK, NOT CONNECTED WITH ODOMETER
137	30031610	1	DO NOT MOVE LIGHT, WHELEN TIR3 LED
138	30031650	1	DO NOT MOVE ALARM
139	30031675	1	DO NOT MOVE DISENGAGE BUTTON
140	29930210	1	DELETE MAPBOOK SLOT ON FRONT BREAKER PANEL
141	29910100	1	PROGRAMMABLE LOAD MANAGER, CLASS-1 SUPERNODE II
142	30031100	1	HIGH IDLE SWITCH
143	11040000	1	CAB ACCESSORY FUSE PANEL

Line	Item #	Qty	Item Description/Comments
144	84541540	1	POWER & GROUND STUDS, UPPER COMMAND CONSOLE
145	84541545	1	POWER & GROUND STUDS, LOWER COMMAND CONSOLE
146	30110000	1	VEHICLE DATA RECORDER, AKRON/WELDON
147	30031810	2	12V POWER POINT (2)
148	30031830	4	12V DUAL POWER POINT, USB/USBC, POWERWERX (4)
149	33510030	1	INTERIOR CAB LIGHTS, WHELEN 6" ROUND RED/CLEAR LED (2)
150	34010030	1	INTERIOR CREW LIGHTS, WHELEN 6" ROUND RED/CLEAR LED (2)
151	33530652	1	INTERIOR CAB DOOR WARNING LIGHTS, WHELEN 500 TIR6 LED, 50*03Z*R (QTY 4)
152	28010750	1	DEFROSTER, HEATER & A/C, SEVERE CLIMATE (TM-31)
153	28020500	1	AIR CONDITIONING WARRANTY, 1 YEAR
154	28090003	1	HEAT TO FEET
155	28030500	1	DEFROSTER DUCTWORK, ENTIRE WINDSHIELD
156	11031687	1	TOP HEAT/AC STORAGE, TOOL MOUNTING PLATE, 25" x 19.5"
157	38510104	1	DRIVER'S SEAT, BOSTROM SIERRA HIGH BACK AIR RIDE ABTS (DURAWEAR PLUS, LOW SEAM)
158	38340110	1	PRIMARY SEAT POSITION
159	38350100	1	SEAT BELT CONFIGURATION, PULL FROM LEFT SHOULDER TO BUCKLE AT RIGHT HIP
160	38320000	1	HELMET STORED IN COMPARTMENT
161	39010118	1	OFFICER'S SEAT, BOSTROM TANKER 450, ABTS SCBA (DURAWEAR PLUS, LOW SEAM)
162	38340110	1	PRIMARY SEAT POSITION
163	38350200	1	SEAT BELT CONFIGURATION, PULL FROM RIGHT SHOULDER TO BUCKLE AT LEFT HIP
164	39030020	1	OFFICER'S SEAT COMPT, FRONT DOOR
165	38320000	1	HELMET STORED IN COMPARTMENT
166	39521129	1	CREW SEAT 1, BOSTROM TANKER 450, ABTS SCBA (DURAWEAR PLUS, LOW SEAM)
167	38340110	1	PRIMARY SEAT POSITION
168	38350200	1	SEAT BELT CONFIGURATION, PULL FROM RIGHT SHOULDER TO BUCKLE AT LEFT HIP
169	38320000	1	HELMET STORED IN COMPARTMENT

Line	Item #	Qty	Item Description/Comments
170	39521130	1	CREW SEAT 2, BOSTROM TANKER 450, ABTS SCBA (DURAWEAR PLUS, LOW SEAM)
171	38340110	1	PRIMARY SEAT POSITION
172	38350100	1	SEAT BELT CONFIGURATION, PULL FROM LEFT SHOULDER TO BUCKLE AT RIGHT HIP
173	38320000	1	HELMET STORED IN COMPARTMENT
174	11031825	1	EMS CABINET, FORWARD FACING, DOUBLE ON CREW SEAT RISER (AERIAL)
175	11032250	1	INTERIOR ACCESS, ROLL-UP DOOR, AMDOR
176	11032415	1	INTERIOR COMPARTMENT DOOR LOCK
177	11032312	1	ADJUSTABLE SHELVES, EMS COMPT (2)
178	39550200	1	SEAT COLOR, BLACK
179	39610000	3	SCBA BRACKETS, BOSTROM, SECURE ALL (3)
180	38410000	1	SEAT BELT WARNING SYSTEM, AKRON / WELDON
181	39710000	1	DOUBLE CREW SEAT COMPT, SIDE DOORS
182	84541750	2	INSTALLATION OF 2-WAY RADIO ANTENNA BASE MOUNT W/CABLE (2)
183	30080160	1	HD STEREO, JENSEN, AM/FM/WB/CD/BT
184	84561015	1	CAMERA SYSTEM, FRC, INVIEW TRUEVIEW, TWO CAMERAS (WIRED)
<b>PUMP &amp; PLUMBING</b>			
185	60012555	1	QMAX-2000 GPM 6" SUCTION SINGLE STAGE PUMP
186	60025000	1	GEARBOX, HALE, G-SERIES, REAR MOUNTED
187	60026000	1	PUMP PACKING, HALE
188	60031005	1	ALLOY ANODES, HALE (2)
189	60035123	1	PUMP TEST, THIRD PARTY TESTING
190	61510010	1	DELETE AUXILIARY COOLER (HEAT EXCHANGER)
191	62010002	1	STAINLESS STEEL PIPING
192	66020100	1	3" TANK TO PUMP W/CHECK VALVE
193	61720100	1	VALVE, AKRON HEAVY DUTY
194	61770120	1	ACTUATOR, VALVE, PUSH/PULL HANDLE, INNOVATIVE CONTROLS
195	73010200	1	TANK FILL 2"

Line	Item #	Qty	Item Description/Comments
196	61720100	1	VALVE, AKRON HEAVY DUTY
197	61770120	1	ACTUATOR, VALVE, PUSH/PULL HANDLE, INNOVATIVE CONTROLS
198	61010405	1	PRESSURE GOVERNOR, CLASS 1 TPGJ1939
199	61210410	1	INTAKE PRESSURE CONTROL, TFT A1831
200	63027300	1	4" WATERWAY INLET, REAR
201	61720410	1	VALVE, CHECK VALVE (REAR WATERWAY INLET)
202	63021100	1	6" MAIN SUCTION, LEFT SIDE
203	65030000	1	2.5" LEFT SIDE INLET
204	61720100	1	VALVE, AKRON HEAVY DUTY
205	61770100	1	ACTUATOR, VALVE, SWING HANDLE
206	60036010	1	THREADS, NST
207	63025100	1	6" MAIN SUCTION, RIGHT SIDE
208	64030000	1	2.5" RIGHT SIDE INLET
209	61720100	1	VALVE, AKRON HEAVY DUTY
210	61770100	1	ACTUATOR, VALVE, SWING HANDLE
211	60036010	1	THREADS, NST
212	70525125	1	2.5" DISCHARGE, LEFT - POSITION 1
213	61720100	1	VALVE, AKRON HEAVY DUTY
214	61770100	1	ACTUATOR, VALVE, SWING HANDLE
215	77021015	1	GAUGE, DISCH, INNOVATIVE CONTROLS TC SERIES, 2.5"
216	61810150	1	DISCHARGE TERMINATION, 30 DEGREE ELBOW
217	60036010	1	THREADS, NST
218	70525125	1	2.5" DISCHARGE, LEFT - POSITION 2
219	61720100	1	VALVE, AKRON HEAVY DUTY
220	61770100	1	ACTUATOR, VALVE, SWING HANDLE
221	77021015	1	GAUGE, DISCH, INNOVATIVE CONTROLS TC SERIES, 2.5"

Line	Item #	Qty	Item Description/Comments
222	61810150	1	DISCHARGE TERMINATION, 30 DEGREE ELBOW
223	60036010	1	THREADS, NST
224	71025130	1	3" DISCHARGE, RIGHT - POSITION 3
225	61720110	1	VALVE, AKRON SLOW CLOSE
226	61770100	1	ACTUATOR, VALVE, SWING HANDLE
227	77021015	1	GAUGE, DISCH, INNOVATIVE CONTROLS TC SERIES, 2.5"
228	61810160	1	DISCHARGE TERMINATION, STRAIGHT
229	60036010	1	THREADS, NST
230	61840267	1	ADAPTER, 3" NST FE X 5" STORZ, 30-DEGREE W/CAP & CHAIN, TFT
231	71025125	1	2.5" DISCHARGE, RIGHT - POSITION 4
232	61720100	1	VALVE, AKRON HEAVY DUTY
233	61770100	1	ACTUATOR, VALVE, SWING HANDLE
234	77021015	1	GAUGE, DISCH, INNOVATIVE CONTROLS TC SERIES, 2.5"
235	61810150	1	DISCHARGE TERMINATION, 30 DEGREE ELBOW
236	60036010	1	THREADS, NST
237	71930800	1	DISCHARGE 2.5" FRONT/LEFT OF MAIN HOSEBED
238	61720100	1	VALVE, AKRON HEAVY DUTY
239	61770120	1	ACTUATOR, VALVE, PUSH/PULL HANDLE, INNOVATIVE CONTROLS
240	77021015	1	GAUGE, DISCH, INNOVATIVE CONTROLS TC SERIES, 2.5"
241	61810160	1	DISCHARGE TERMINATION, STRAIGHT
242	60036010	1	THREADS, NST
243	72230250	1	DISCHARGE 2.5" FRONT BUMPER, 2.5" PLUMBING, OFFICER'S SIDE (AERIALS)
244	61720100	1	VALVE, AKRON HEAVY DUTY
245	61770120	1	ACTUATOR, VALVE, PUSH/PULL HANDLE, INNOVATIVE CONTROLS
246	77021015	1	GAUGE, DISCH, INNOVATIVE CONTROLS TC SERIES, 2.5"
247	60036010	1	THREADS, NST

Line	Item #	Qty	Item Description/Comments
248	72240100	1	VERTICAL STOP PINS FOR FRONT BUMPER SWIVEL
249	72810000	1	TWO CROSSLAYS 2" VALVE-PIPING 1.5" SWIVEL
250	61720100	2	VALVE, AKRON HEAVY DUTY (2)
251	61770120	2	ACTUATOR, VALVE, PUSH/PULL HANDLE, INNOVATIVE CONTROLS (2)
252	77021015	2	GAUGE, DISCH, INNOVATIVE CONTROLS TC SERIES, 2.5" (2)
253	60036010	2	THREADS, NST (2)
254	72910510	1	COVER, VINYL FOR CROSSLAYS (AERIALS)
255	72932201	1	COVER FASTENERS, BUNGIE CORDS WITH RED TAB
256	61742000	1	MASTER PUMP DRAIN, MULTIPOINT
257	61730005	9	DRAIN VALVES, INNOVATIVE CONTROLS, LIFT-UP (9)
258	78521435	1	WATERWAY CONTROL, 3" VALVE, AKRON 9335 ELECTRIC ACTUATOR
259	61910100	1	WATERWAY DRAIN VALVE, AKRON 1.5" PUSH/PULL CONTROL
<b>PUMP PANEL</b>			
260	74920320	1	MT SM2 - SIDE MOUNT PUMP PANEL (FOR REAR MOUNT AERIAL)
261	74930510	1	PANEL FINISH, BRUSHED STS
262	74930900	1	PUMP PANEL SWITCH CLUSTER, IC
263	74931000	1	ESCUTCHEON PLATES
264	74931050	1	COLOR CODING
265	74931210	1	PUMP MODULE FRAMEWORK, NON-PAINTED
266	74931310	1	PUMP FINISH, PAINTED BY PUMP MFG
267	74931520	1	PLUMBING FINISH, NON-PAINTED
268	74931620	1	EXTERIOR DUNNAGE AREA PANEL, BRUSHED STS
269	75510261	1	PUMP OPERATOR LIGHTS, AMDOR H2O LED STRIP
270	75530136	1	PUMP PANEL LIGHTS OFFICER'S SIDE, AMDOR H2O LED STRIP
271	76010105	1	PUMP PANEL GAUGES & CONTROLS
272	60028050	1	PUMP PRIMER, TRIDENT, AIR
273	60028310	1	(1) PRIMER BUTTON - MAIN SUCTION

Line	Item #	Qty	Item Description/Comments
274	76025100	1	COMPRESSION FITTINGS ON AIR SYSTEM (CTZ PUMP MODULE)
275	76031950	1	AIR OUTLET, DRIVER'S SIDE PUMP PANEL, WITH 25' OF HOSE
276	76030805	1	HALE TRV-L THERMAL RELIEF VALVE WITH LIGHT AT PUMP PANEL
277	76031900	1	AIR HORN PUSH BUTTON SWITCH ON PUMP PANEL
278	76520100	1	GAUGES, MASTER, CLASS 1 4.5"
279	77510090	1	GAUGE, WATER LEVEL, CLASS 1, INTELLI-TANK ITL-40
<b>WATER TANK</b>			
280	83525000	1	WATER TANK BRAND, UNSPECIFIED
281	83520425	1	WATER TANK, 500 GAL, POLY
282	83530110	1	WATER TANK WARRANTY, LIFETIME
<b>BODY</b>			
283	80030001	1	STAINLESS STEEL SUBFRAME FOR BODY, SINGLE AXLE AERIALS
284	80126110	1	BODY SAA-RM1, LEFT HIGH / RIGHT HIGH
<b>BODY COMPARTMENTS</b>			
285	81165705	1	UNISTRUT TRACK IN COMPTS
286	80220340	1	COMPT DOORS, AMDOR ROLL-UP, PAINTED
287	80230920	1	ROLL UP DOORS WARRANTY, AMDOR, 3 YEARS
288	80230200	8	COMPT DOOR LOCKS, KEYED ALIKE (8)
289	84531110	1	COMPT LIGHTING, AMDOR LED LIGHT STRIPS, 2 PER COMPT
<b>BODY EXTERIOR</b>			
290	81320325	1	HOSEBED, SLR75 (SAARM1)
291	81410400	1	COVERS, TWO ALUMINUM, MAIN HOSE BED
292	81431200	1	REAR HOSEBED COVER, VINYL
293	81440201	1	COVER FASTENERS, BUNGIE CORDS WITH RED TAB
294	81332030	1	HOSEBED LIGHTING, FRONT, WHELEN 2G LEDS
295	81910350	1	HANDRAILS, KNURLED STS, SLR75
296	82014350	1	STEPS, IC FOLD DOWN W/LIGHT (SLR75/SLR108)
297	82520000	1	RUB RAILS, EXTRUDED ALUM

Line	Item #	Qty	Item Description/Comments
298	83010150	1	ALUMINUM TREADPLATE (AERIALS)
299	83030425	2	GRIP STRUT ON RUNNING BOARD (2)
300	83030610	1	REAR FENDERS, STAINLESS STEEL (SINGLE AXLE AERIALS & SLTDA105)
301	80231240	1	8 SCBA CYLINDER COMPTS (2 DBL, EA SIDE)
302	80290310	4	DOOR FINISH, BRUSHED STAINLESS, SINGLE/DOUBLE SCBA COMPT (4)
303	89020330	1	LADDERS, DUO-SAFETY QUINT (MT) 85' 16R', 24'-2sec, 35'-3sec & 10'F
304	89030560	1	DUO-SAFETY 16' ROOF LADDER, 875A (1)
305	89510250	1	LADDER CHUTE (SLR75)
306	89520220	1	LADDER ENCLOSURE, SMOOTH ALUM DOOR
<b>ELECTRICAL</b>			
307	84550110	1	LICENSE PLATE BRACKET W/ LIGHT, LED
308	84511100	1	BODY ELECTRICAL DESCRIPTION
309	84520000	1	BACK UP ALARM, ECCO SA917
310	85010420	1	TAILLIGHTS, WHELEN M6 SERIES, LED STOP/TAIL/TURN/REVERSE, QUAD HOUSING (PAIR)
311	85110100	1	ICC LIGHTS, LED
312	85510220	1	STEP LIGHTS, LED, REAR BODY & WHELEN 2G AT PUMP PANEL
313	85710040	1	UNDERCARRIAGE GROUND LIGHTS, WHELEN 2G LED
314	85730040	2	ADDITIONAL GROUND LIGHT, WHELEN 2G LED (2)
315	86528999	1	DELETE REAR WORK LIGHTS
316	86600220	1	OPTICAL WARNING SYSTEM, UPPER (SLR75)
317	86610300	1	UPPER WARNING LIGHTS, ZONE A (FRONT), WHELEN MINI FREEDOM IV 21" LED LIGHT BARS, F4NMINI (PAIR)
318	86920100	1	UPPER ZONE A LIGHTBAR, STANDARD CONFIGURATION
319	86699999	1	UPPER WARNING LIGHTS, ZONE B (OFFICER'S SIDE), COVERED BY ZONES A & C
320	86710105	1	UPPER WARNING LIGHTS, ZONE C (REAR), WHELEN LED BEACONS, L31 (PAIR)
321	86899999	1	UPPER WARNING LIGHTS, ZONE D (DRIVER'S SIDE), COVERED BY ZONES A & C
322	87100220	1	OPTICAL WARNING SYSTEM, LOWER (SLR75)
323	87110210	1	LOWER WARNING LIGHTS, ZONE A (FRONT), WHELEN M6 LED, M6* (QTY 4)

Line	Item #	Qty	Item Description/Comments
324	87811130	1	LOWER, ZONE A - MOUNTING LOCATION (DUAL HOUSINGS)
325	87210202	1	LOWER WARNING LIGHTS, ZONE B (OFFICER'S SIDE), WHELEN M6 LED, M6* (QTY 2), T-SERIES LED, TSS0* (QTY 1)
326	87812120	1	LOWER, ZONE B - MOUNTING LOCATION (SLR75)
327	87310200	1	LOWER WARNING LIGHTS, ZONE C (REAR), WHELEN M6 LED, M6* (QTY 2)
328	87410202	1	LOWER WARNING LIGHTS, ZONE D (DRIVER'S SIDE), WHELEN M6 LED, M6* (QTY 2), T-SERIES LED TSS0* (QTY 1)
329	87814120	1	LOWER, ZONE D - MOUNTING LOCATION (SLR75)
330	87537750	1	ADDITIONAL WARNING LIGHTS, WHELEN M6V2* LED (PAIR) (1)
331	87537505	1	WARNING LIGHT, ROTO-RAY, LED
332	88393000	1	SCENE LIGHTS, FIRETECH 30K LUMENS, 12V LED, 72" 3-PIECE BROW, W/INTEGRATED ICCS FT-B-72-ML-3PKIT-* (1)
333	88393050	2	SCENE LIGHT, FIRETECH GUARDIAN 10K, 12V LED, SURFACE MOUNT, FT-GSM (2)
334	88393100	2	SCENE LIGHT, FIRETECH MB SINGLE STACK 12", 12V LED, FIXED, 9 LED, FT-MB-9-FT-* (2)
335	88393109	4	SCENE LIGHT, FIRETECH MB SINGLE STACK 42", 12V LED, FIXED, 33 LED, FT-MB-33-FT-* (4)
336	88399940	4	ADDITIONAL SWITCH, 3-WAY FOR 12V LIGHTS (EA) (4)
<b>GENERATOR &amp; ACCESSORIES</b>			
337	88230202	1	GENERATOR, SMART POWER, 6KW HYD, MT
338	88238510	1	GENERATOR WARRANTY, SMART POWER, 5 YEARS
339	88250405	1	CIRCUIT BREAKER PANEL WITH 8 SPACES FOR BREAKERS
340	88251100	1	BREAKER PANEL, STD LOCATION (L1)
341	88431205	1	HANNAY ECR-1616-17-18 REEL W/150' 10/3 (1)
342	88433010	1	MOUNTING OF ELEC CORD REEL IN BODY COMPT
343	88432000	1	AKRON FOUR-WAY RECEPTACLE BOX, WIRED TO REEL CABLE (1)
344	88390400	1	SCENE LIGHT, FIRETECH FT-SL-15, 20K LUMENS, 120V LED, TELE, (1)
345	88399959	1	SCUFF PLATES FOR TELE LIGHTS - NOT PROVIDED
346	88399920	1	ADDITIONAL SWITCH, 3-WAY FOR 120/240V LIGHTS (EA) (1)
<b>AERIAL</b>			
347	10040225	1	MODEL, SLR75, AERIAL COMPONENTS
348	95010375	1	AERIAL LADDER, SLR75

Line	Item #	Qty	Item Description/Comments
349	95012110	1	LIFTING CYLINDERS - SLR75
350	95012210	1	EXTENSION & RETRACTION - SLR75
351	95016150	1	TURNTABLE/ROTATION - SLR75
352	95016165	1	ROTATION LIMITING SYSTEM & SMART BOOM WARNING SYSTEM
353	95016170	1	ROTATION LIMITING ALARM , FLOYD BELL US-09-515-S
354	95016175	1	TURNTABLE ACCESS, REAR, FIXED STEPS CENTER - SLR75
355	95015510	1	HYDRAULIC & ELECTRIC SWIVELS - SLR75
356	95015230	1	HYDRAULIC SYSTEM - SLR75
357	95015310	1	EMERGENCY AUXILIARY HYDRAULIC MOTOR - SLR75/SLR108
358	95015410	1	INTERLOCK - SLR75
359	95022110	1	JACKS - H-STYLE - SLR75
360	95022150	1	AERIAL JACKS ALARM, ECCO DT500
361	95025315	1	CONTROL STATION - SLR75
362	95025345	1	REMOTE CONTROL AERIAL & MONITOR - SL75, SLR75, SLR108
363	95025405	1	DATA PLAQUES - AERIALS
364	95025505	1	OPERATIONAL TEST - LADDERS
365	95025602	1	LADDER TEST, THIRD PARTY TESTING
366	95033350	1	WATERWAY - SLR75
367	95033450	1	WATERWAY WARRANTY, AMITY, 10 YEARS
368	95050140	1	AERIAL SPOT LIGHTS - (4) FIRETECH FT-WL-X-5-S-B, LED (SA/SL/SLR)
369	95050190	1	LADDER LIGHTING SYSTEM, FIRETECH FT-WL-2000-S-B, LED (SA/SL/SLR75, SP70, SLR108)
370	95055340	1	MONITOR, TFT FLEX ELEC YN-E15A W/M-ERP-1500 NOZZLE (SA/SL/SLR)
371	95060115	1	INTERCOM SYSTEM, FRC ACT 2-STATION (SA75/SL75/SLR75/SLR108)
372	95040410	1	DOUBLE LIFTING RINGS, 250 LB. EA
373	95080200	1	STOKES BASKET MOUNTED ON BASE SECTION OF BOOM
374	96088888	1	SPECIAL ITEM, Roof Ladder mounted to base section of aerial
<b>PAINT &amp; FINISH</b>			

Line	Item #	Qty	Item Description/Comments
375	90010050	1	STAINLESS PAINT SCHEME - STS PPRS & MINITOWER
376	90030007	1	TWO TONE CAB
377	90029910	1	PAINT BREAK #1 - BOTTOM OF WINDSHIELD
378	90030170	1	PAINT FRAME RAILS, FUEL TANK, & LOWER AERIAL COMPONENTS - BLACK (SINGLE AXLE)
379	90030032	1	PAINT, TURNTABLE, SIDE PLATES & LIFT CYLINDER OTHER THAN SILVER
380	90030190	1	TEXTURED FRAME RAIL COATING, PLUMBING AREA
381	90030076	1	SIDE METAL PAINTED ON HIGH SIDE, BOTH SIDES
382	90030015	1	A/C CONDENSER PAINTED ROOF COLOR
383	90088888	1	SPECIAL ITEM, Paint Extension Cylinders, Sheave Beams & Monitor Brackets other than Silver
384	90600520	1	REFLECTIVE MATERIAL, TIP OF AERIAL LADDER, REFLEXITE
385	90630610	1	1/2" 22KT GOLD STRIPE W/PRINTED EDGES AT CAB PAINT BREAK
386	90684120	1	CHEVRON STRIPING, LADDER ENCLOSURE DOOR, REFLEXITE
387	90682150	1	CHEVRON STRIPING, REAR BODY OUTBOARD, REFLEXITE (Aerial Ladders, Rear Mount)
388	90710300	1	BOOM SIGN, APPROX 66" x 10"
<b>EQUIPMENT</b>			
389	91010000	1	MISC EQUIP - (1) PINT TOUCH-UP PAINT, STAINLESS STEEL NUTS & BOLTS
390	89050515	1	PIKE POLE STORAGE TUBES (3), REAR OF OFFICER'S SIDE
<b>COMPLETION &amp; WARRANTY</b>			
391	99010100	1	MANUALS, ELECTRONIC VERSION (2-USB)
392	99031195	1	DEALER DELIVERY
393	99520310	1	WARRANTY, ONE YEAR - AERIALS (HILLIARD)
394	99521100	1	WARRANTY, FRAME, LIFETIME
395	99521200	1	WARRANTY, CAB STRUCTURAL, 10 YR.
396	99521300	1	WARRANTY, BODY STRUCTURAL, 10 YR.
397	99521400	1	WARRANTY, PAINT, 10 YR.
398	99521500	1	WARRANTY, AERIAL MECHANICAL, 2 YR.
399	99521600	1	WARRANTY, AERIAL STRUCTURAL, 30 YR.

Line	Item #	Qty	Item Description/Comments
400	99521900	1	WARRANTIES, MAJOR VENDOR COMPONENTS
<b>DEALER SUPPLIED</b>			
401	Other	1	DEALER SUPPLIED - OTHER - TFT INTAKE VALVE
402	Other	1	DEALER SUPPLIED - OTHER - CUSTOM CONSOLE
403	Other	1	DEALER SUPPLIED - OTHER - INTERCOM SYSTEM FIRECOM WIRELESS
404	Other	1	DEALER SUPPLIED - OTHER - ROLL UP DOOR DRIP PANS
405	Other	1	DEALER SUPPLIED - OTHER - SHELVING TRAYS TURTLE TILE
406	Other	1	DEALER SUPPLIED - OTHER - EQUIPMENT MOUNTING
407	Other	1	DEALER SUPPLIED - OTHER - ZIAMATIC WHEEL CHOCKS
408	Other	1	DEALER SUPPLIED - OTHER - MOUNT CUSTOMER SUPPLIED RADIO
409	Other	1	DEALER SUPPLIED - OTHER - 17" LITTLE GIANT LADDER
410	Other	1	DEALER SUPPLIED - OTHER - WIRING FOR FUTURE INSTALLATIONS IN CAB
411		1	COOPERATIVE PURCHASING AGENCY FEES (Sourcewell)